



COLUMN

Cover image:

SANYO DENKI AMERICA, INC.

1995

In April 1995, we established a new sales subsidiary, SANYO DENKI AMERICA, INC., in Torrance, California to expand the sales of our products and develop new markets on the US West Coast.

Located about a 30-minute drive south of Los Angeles International Airport, the office has served as a key base for our operations in the United States. At the time, Los Angeles was already a prominent economic and cultural center, marked by its skyline of high-rise buildings.

The subsidiary initially focused on selling CPU Coolers to Intel, aiming to achieve a first-year sales target of 3 billion yen. It has also engaged in duties such as obtaining safety certifications and procuring materials, playing an essential role in expanding our business in the region.

In January 2024, it underwent a major revamp involving factory and production line expansions, enhancing its assembly capabilities for servo amplifiers, servo motors, and cooling fans.

SANYO DENKI Group’s SDGs Initiatives Executive Operating Officer Koichi Uchibori 1

Feature: Our Initiatives for SDGs and Environmental Technologies 3

Development of Eco-Design Products
for Achieving Carbon Neutrality Akio Miyahara 3

Feature: Our Products and SDGs 6

■ **San Ace Products**

San Ace Products and SDGs Honami Osawa 6

60 × 60 × 76 mm *San Ace 60L 9CRLB* Type
Long Life Counter Rotating Fan Naoya Inada and Others 10

60 × 60 × 56 mm *San Ace 60 9CRH* Type
Counter Rotating Fan Yukihiro Nagatsuka and Others 15

■ **SANUPS Products**

SANUPS Products and SDGs Masayuki Shibata and Others 20

Development of the *SANUPS W83A*
Renewable Energy Inverter Takuya Ota and Others 27

■ **SANMOTION Products**

SANMOTION Products and SDGs Naohiro Ito and Others 35

Expanded Lineup of the *SANMOTION G*
AC Servo Systems Tsuyoshi Kobayashi and Others 41

SANYO DENKI Group's SDGs Initiatives

Koichi Uchibori Executive Operating Officer

The world is currently facing a wide range of issues. To address and resolve these crises, the Sustainable Development Goals (SDGs) were established by the United Nations, outlining 17 global goals (17 SDGs) to be achieved in 15 years from 2016 to 2030, and efforts to achieve these goals are underway around the world.

Under our corporate philosophy, established in 1996, which is to “aim to help all people achieve happiness,” SANYO DENKI Group has provided society with a number of high-efficiency and energy-saving products by leveraging our technologies and strengths.

As our corporate philosophy states, we aim to build a society where “all people achieve happiness,” which coincides with the sustainable and prosperous society that the SDGs aim to achieve. Under this corporate philosophy, our group has become more conscious about how we relate to the SDGs and set 15 key goals in our new business plan for 2024 onwards. With these goals, we have set 2024 target values by envisioning where we want to stand in 2030, the final year of the SDGs. To achieve these 15 key goals, we encourage all Group employees to be more aware of how the SDGs are related to their duties and promote relevant initiatives.

The 17 goals are not independent of one another. On the contrary, they are closely related and influence each other. Targets under one goal can help achieve another goal, forming a network of targets. This is also referred to as the SDG domino effect. The starting point of the SDG domino effect—where social issues start to be solved one after another—can be our products and services. To create a product or service that is significant enough to trigger such a chain reaction, it will be necessary to grow the Group's core competencies (the ability to initiate the chain reaction, or in other words, unique strengths and skills that give a company a competitive edge).

To contribute to SDGs in product development, we develop new products and technologies based on the following three technologies: technology for protecting the global environment, technology for using new energy sources and saving energy, and technology for protecting people's health and safety. Products developed based on these three technologies not only perform

superbly on their own but also create new value when incorporated into our customers' products and expected to serve as the trigger of a chain reaction leading to solving the social issues of the 17 SDGs.

We offer Eco Products, designed to meet our eco-design requirements and have a lower environmental impact than our existing products and competitors' products on the market. In 2024, we revised the evaluation criteria and launched Eco Product Plus, a new eco-design product category with an even lower environmental impact. Our Eco Products have better energy efficiency and environmental impact performance than our conventional products. Not only are they very effective in reducing CO₂ emissions during use, but they also have a higher recycling rate at the time of disposal as well as superb basic performance.

As climate change has become a critical issue in society, we are required to take responsibility for disclosing the CO₂ emissions that our products generate over their service life and make efforts to reduce them. In FY 2022, we began disclosing our CO₂-equivalent emissions from the previous fiscal year. This data shows that the CO₂-equivalent emissions during the "use of sold products" account for most of our emissions. Therefore, to effectively reduce our CO₂ emissions, we must develop and sell products with low power consumption and environmental impact. Accordingly, we have set this as a key goal for the SDGs.

Our Eco Products, which excel in energy efficiency and environmental impact reduction, will not only help us reduce CO₂ emissions greatly but also help our customers and society reduce emissions. As such, our group has set and is actively working toward a goal of achieving an 80% sales ratio of Eco Products by FY 2030.

This Technical Report focuses on how we are related to the SDGs and introduces our new products developed at each business company, highlighting their roles, features, and technologies. By offering top-brand products and services, we will continue to contribute to realizing a sustainable and circular society where both business growth and environmental protection can be achieved.

Development of Eco-Design Products for Achieving Carbon Neutrality

Akio Miyahara

1. Introduction

In 2022, we began disclosing the CO₂ emissions generated from our business activities.⁽¹⁾ Furthermore, in March 2023, we announced our medium- and long-term CO₂ emissions reduction targets to promote our carbon neutrality initiatives.

Our products are energy conversion devices that turn electrical energy into fluid or mechanical energy. Most of our CO₂ emissions result from the power consumed by our products during use, so reducing their power consumption is a key step toward achieving carbon neutrality.

This article presents an overview of eco-design, which is our design guidelines to reduce the environmental impact of products. Eco-design includes initiatives to reduce power consumption and CO₂ emissions. We will also highlight our Eco Products, which are new products developed under eco-design to meet our own standards.

2. Our Current Carbon Neutrality Status and Initiatives

2.1 Our CO₂ emissions

Starting in 2022, we began disclosing the CO₂ emissions across our entire supply chain in accordance with the scopes defined by the global standard Greenhouse Gas Protocol.⁽¹⁾ Figure 1⁽²⁾ shows our latest emissions in FY 2023.

Greenhouse gas emissions are classified under three scopes. Scope 1 involves our direct CO₂ emissions, which we generate through the combustion of fuels like A-type heavy oil and gases. Scope 2 covers indirect CO₂ emissions resulting from the electricity purchased from electricity companies. Scope 3 refers to all other indirect emissions not covered in Scopes 1 and 2. These are emissions that occur across the entire supply chain, ranging from the production and transportation of raw part materials we purchase to the manufacturing, use, and disposal of our products.

Our Scope 1 and 2 CO₂ emissions account for less than

1% of the total for all scopes. On the other hand, emissions from the “during product use” category in Scope 3 account for approximately 94% of the total, followed by emissions from the “raw materials” category in Scope 3.

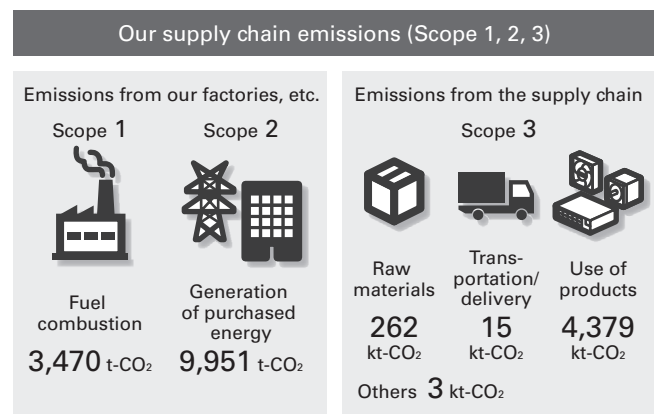

Fig. 1 FY 2023 CO₂ emissions by Scope

- Scope 3 emissions were calculated for 7 categories (1, 3, 4, 5, 6, 7, and 11) of the 15 categories
- Our bases under Scopes 1, 2: All group companies in Japan, SANYO DENKI PHILIPPINES, INC., and SANYO DENKI AMERICA, INC.

This shows that reducing power consumption of our products—energy conversion devices—during use greatly contributes to reducing CO₂ emissions. Consequently, we believe that the promotion of designing products that minimize environmental impact in product development, which is the foundation of our business, will contribute the most to achieving carbon neutrality.

2.2 CO₂ emission targets

In March 2023, we announced our medium- and long-term CO₂ emissions reduction targets,⁽³⁾ as shown in Table 1. These targets were made public to help our stakeholders understand our stance and thoughts on environmental issues and carbon neutrality. These targets are quantitative goals for reducing Scope 1 and 2 emissions, and we have

formulated initiatives to achieve these reductions.

For Scope 3, which makes up the largest share of our emissions, we are making efforts mainly through our product development and design. Specific initiatives include the promotion of the eco-design approach and the establishment and implementation of Eco Products and Eco Products Plus categories.

Setting targets for Scope 3 and expanding the extent of coverage in target setting to include other group companies are tasks to be addressed in the future.

Table 1 Medium/Long-term CO₂ emissions reduction targets

FY 2030 targets	46% reduction
FY 2050 targets	Achieving carbon neutrality

- Reference year: FY 2017
- Applicable bases: SANYO DENKI CO., LTD., SANYO DENKI Techno Service CO., LTD., and SANYO DENKI IT Solution CO., LTD.

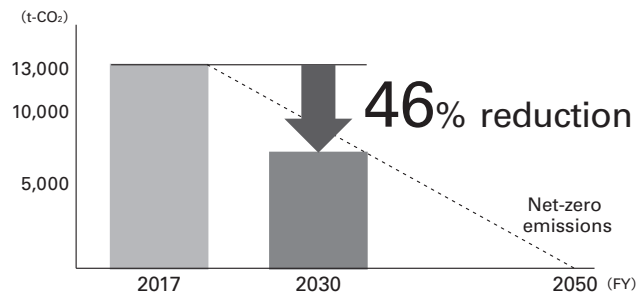

3. Overview of Eco-Design

Eco-design refers to a design approach that focuses on minimizing negative environmental impacts of products such as preventing pollution. Key considerations include resource savings, material selection, energy efficiency of parts, products, and production processes, reusability, maintainability, modularity, and recyclability.

In addition, the eco-design approach aims to reduce harmful environmental impacts at every stage of a product life cycle—from the procurement of parts and materials to manufacturing, distribution, use, recycling, and disposal. To this end, we study and examine using the life cycle assessment (LCA) approach.

The specific considerations and guidelines are shown in Table 2.

Table 2 Eco-design considerations and guidelines

	Items to consider	Guideline
1	Material	Selection, recyclability, reduction of harmful substances
2	Resource saving	Weight/size reduction, recycling, long life
3	Maintenance	Environmental impact, cost reduction
4	Disassembly process	Ease of disassembly and structural considerations
5	Labeling	Information on recycling and disposal
6	Energy saving	During production, product use, and standby
7	Disposal	Ease of disposal and considerations for the surrounding environment
8	Recycling	Recycling and disposal instructions
9	Packaging material	Structure, materials, labeling
10	LCA rating	Power consumption, CO ₂ emissions

Design engineers take these factors into account in the product development and design stages to reduce negative environmental impacts. Product assessments are conducted to evaluate their environmental performance.

4. Eco Products Overview and Revised Requirements

4.1 Overview of Eco Products

After being developed based on eco-design, products are assessed against eco-design requirements. The products are assessed in comparison with our existing products and competitors' existing products on the market, and those that earn a passing score are certified as Eco Products.

Based on the eco-design considerations outlined above, ten criteria are evaluated for products, while six criteria are evaluated for packaging materials. As an example, Table 3 lists the criteria of a product evaluation and expected environmental impact reductions.

Table 3 Eco-design criteria for products

	Evaluation criteria	Low environmental impact
1	Weight/Size reduction	Resource saving, global warming
2	Long life	Resource saving, global warming
3	Safety, environmental friendliness	Chemical substance control, health and safety
4	Recycling	Resource saving, recycling
5	Product modularity	Resource saving, recycling
6	Disposal	Chemical substance control
7	Collection and transportation	Global warming
8	Information disclosure	Resource saving, recycling
9	Energy saving	Global warming
10	LCA (CO ₂ emissions)	Global warming

Among these criteria, the evaluation score for energy saving is given a greater weight. This is because we believe it is of utmost importance for both the Group and our customers to develop highly efficient, low power consumption products, which help achieve carbon neutrality.

4.2 Revised Eco Products requirements

In 2023, with the aim of helping customers better understand the significance of Eco Products, we revised the eco-design criteria and threshold values.

This revision resulted in the following changes to clarify the benefits to customers.

- A new eco-design qualification category, Eco Products Plus, was set over the Eco Products category. Figure 2 shows the Eco Products and Eco Products Plus symbols and logos.
- Avoided emissions have been added as a new evaluation criterion. This criterion quantitatively demonstrates a product's ability to reduce CO₂ emissions during its use compared to an existing product. We are currently preparing to disclose the avoided emissions data.



Fig. 2 Symbols/logos of Eco Products and Eco Products Plus

By helping customers understand the significance of Eco Products and providing them with more opportunities to use them, we will reduce CO₂ emissions and promote carbon neutrality.

5. Conclusion

This article has introduced our carbon neutrality initiatives and the eco-design approach with Eco Products as a way of achieving it. The key points are as follows.

- (1) We disclosed our CO₂ emissions according to the Scopes defined by the Greenhouse Gas Protocol and released our medium- and long-term CO₂ emissions reduction targets for achieving carbon neutrality.
- (2) Emissions from the “use of sold products” category in Scope 3 account for approximately 94% of our total CO₂ emissions. Consequently, promoting product development using a design approach that reduces a product's environmental impact is the way to go in advancing carbon neutrality.
- (3) We promote the use of the eco-design approach as a way of developing eco-friendly products. We revised the Eco Products evaluation criteria and requirements to help customers better understand its significance. We have set a new category, Eco Products Plus, to promote the development of products with even higher eco-environment performance than Eco Products. Moreover, the “avoided emissions” criterion, a quantitative measure of a product's CO₂ emissions reduction ability, has been added.

Achieving carbon neutrality is a major societal challenge that every member of the Group must work toward with a sense of responsibility. We will continue to contribute to reducing global CO₂ emissions by reducing our CO₂ emissions from electricity and fuel use and by expanding the lineup and sales of Eco Products, which can greatly contribute to achieving carbon neutrality.

Reference

- (1) Environmental Data Book 2022, pp. 8 (2022.7)
- (2) Environmental Data Book 2024, pp. 9 (2024.7)
- (3) Formulated CO₂ emissions reduction initiatives over the medium and long term for achieving carbon neutrality (2023.3)

Author

Akio Miyahara

Environmental Technology Implementation Dept.

60 × 60 × 76 mm San Ace 60L 9CRLB Type Long Life Counter Rotating Fan

Naoya Inada Haruhisa Maruyama Haruka Sakai Koji Ono Honami Osawa

1. Introduction

With the development of an information society, communication devices such as ICT equipment and servers are increasingly essential in supporting our society and economy. As equipment performance rapidly advances, so does its density and the amount of heat generation. Amid such market trends, many customers are making use of counter rotating fans. In addition, equipment installed in critical facilities or remote locations requires high reliability and long life. For this reason, cooling fans are now required to offer extended service life and superior cooling performance.

We have offered the *San Ace 60L 9CRLA* type Long Life Counter Rotating Fan (hereinafter, “current product”). Now, in response to the above-mentioned latest market demands, we have developed and launched the *San Ace 60L 9CRLB* type Long Life Counter Rotating Fan (hereinafter, “new product”).

The new product features reduced power consumption and noise while maintaining a long life. It has also been certified under our own Eco Product standard, which recognizes products that help reduce environmental impact.

This article introduces the features and performance of the new product.



Fig. 1 60 × 60 × 76 mm *San Ace 60L 9CRLB* type

2. Product Features

Figure 1 shows the new product.

The new product achieves higher airflow and static pressure than the current product while maintaining a long service life.

3. Product Overview

3.1 Dimensions

Figure 2 shows the dimensions of the new product. It is designed to be compatible with the current product in dimensions and mounting.

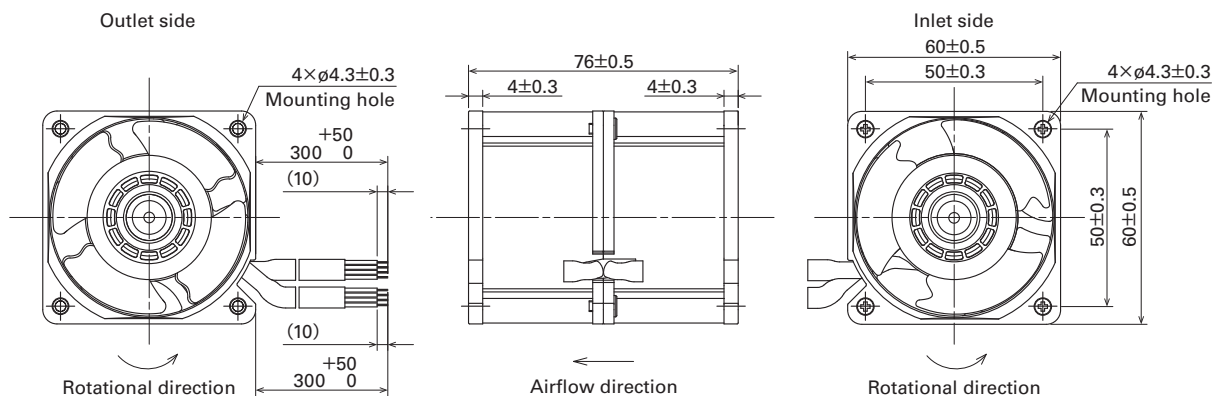

Fig. 2 Dimensions of 60 × 60 × 76 mm *San Ace 60L 9CRLB* type (Unit: mm)

Table 1 General specifications of 60 × 60 × 76 mm *San Ace 60L 9CRLB* type

Model no.	Rated voltage [V]	Operating voltage range [V]	PWM duty cycle* [%]	Rated current [A]	Rated input [W]	Rated speed [min ⁻¹]		Max. airflow		Max. static pressure		Sound pressure level [dB(A)]	Operating temperature range [°C]	Expected life [h]
						Inlet side	Outlet side	[m ³ /min]	[CFM]	[Pa]	[inchH ₂ O]			
9CRLB0612POG001	12	10.8 to 13.2	100	3.6	43.2	19700	18300	2.4	84.8	1500	6.00	75	-20 to +70	100000 at 60°C (135000 at 40°C)
			20	0.28	3.36	5300	4800	0.64	22.6	110	0.44	43		

Note : PWM input frequency is 25 kHz. Speed is 0 min⁻¹ at 0% PWM duty cycle for models without ratings listed at 0%.
The speed when control terminal is open is the same as when the PWM duty cycle is 100%.

3.2 Specifications

3.2.1 General specifications

Table 1 shows the general specifications of the new product.

3.2.2 Airflow vs. static pressure characteristics

Figure 3 shows the airflow vs. static pressure characteristics of the new product.

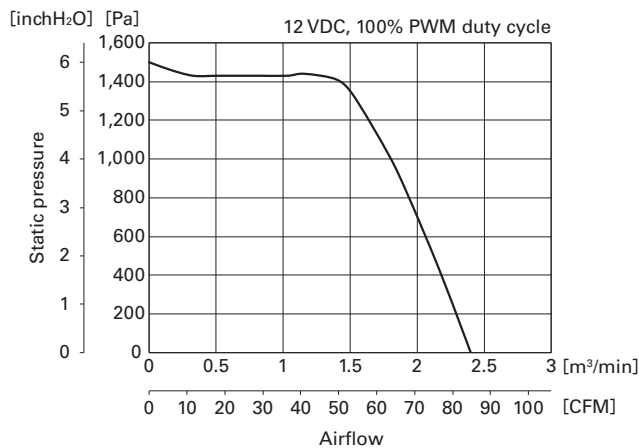

Fig. 3 Airflow vs. static pressure characteristics of the 60 × 60 × 76 mm *San Ace 60L 9CRLB* type

3.2.3 PWM control

The new product comes with PWM control for controlling fan speed.

3.3 Expected life

The new product has an expected life of 100,000 hours at 60°C (survival rate of 90%, run continuously at rated voltage and normal humidity in free air), which is the same as the current product while providing higher airflow and static pressure.

4. Key Points of Development

The new product achieves higher airflow and higher static pressure than the current product while maintaining a long service life. This is achieved through a highly efficient 3-phase drive motor, aerodynamically optimized impeller and frame shapes, and a downsized motor.

The key points of development are as follows.

4.1 Motor design

Achieving higher airflow and static pressure than the current product required a faster speed. Also, a longer service life can be achieved by increasing the efficiency and reducing the power consumption. An effective way to achieve this is to suppress the temperature rise in the bearings. One effective approach was to reduce power consumption by improving motor efficiency. To this end, the new product uses a 3-phase drive motor, which supports both high speed and high efficiency. The motor is small yet more efficient than that of the current product, contributing to low power consumption.

Figure 4 compares the motors of the current and new *San Ace 60L* fans. The current product uses a bipolar drive (single-phase full-wave) motor.



Fig. 4 Motors of the new and current products

4.2 Impeller and frame design

To achieve high airflow, high static pressure, and reduced power consumption, we adopted a 3-blade impeller for the inlet fan. Increasing the blade area leads to high airflow, while reducing the curvature of the blades lessens air load, contributing to reduced power consumption. Additionally, downsizing the motor allows for an increased inclination angle of the blade hub, further enhancing airflow. Simulations and actual equipment evaluations were carried out with various combinations. By optimizing the shapes of the rotor blades and frame spokes against the airflow, we achieved low power consumption and low noise under load. Figure 5 compares the shapes of the new and current rotor blades. Figure 6 shows an example of a simulation that visualizes the airflow.

The new product uses the same die-cast aluminum frame as the current product to ensure strength and effective heat dissipation, contributing to a long service life.

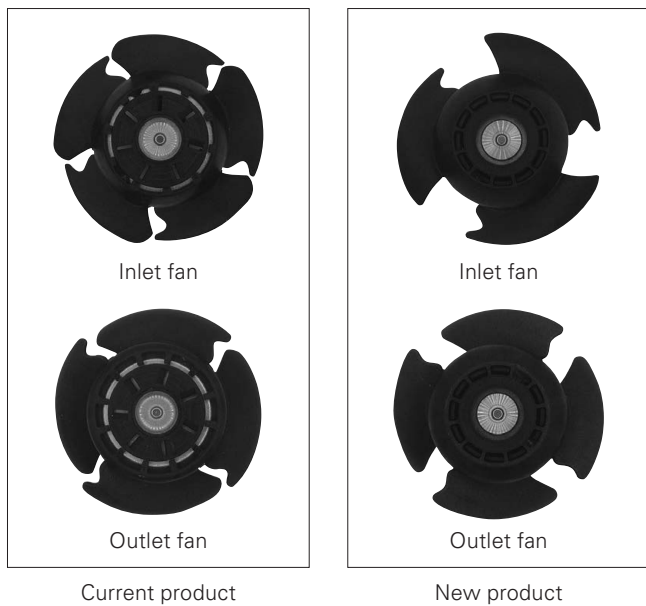

Fig. 5 Rotor blade shape comparison between the new and current products



Fig. 6 Simulation example (Airflow of the new product)

5. Comparison of New and Current Products

5.1 Comparison of airflow vs. static pressure characteristics

Figure 7 compares the airflow vs. static pressure characteristics of the new and current products.

Compared to the current product, the maximum airflow and maximum static pressure of the new product have improved by 15% and 7%, respectively.

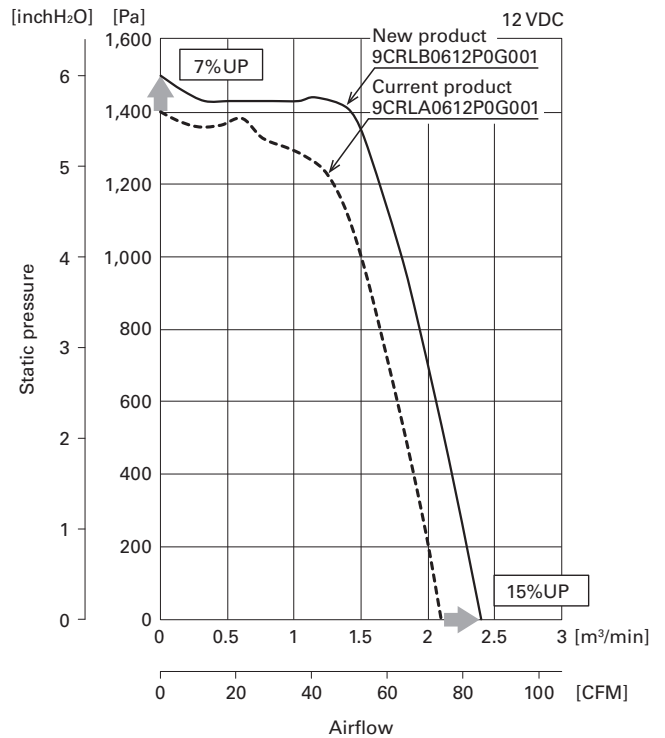

Fig. 7 Airflow vs. static pressure characteristics of the new and current products

5.2 Power consumption and noise comparison

Figure 8 compares the power consumption and noise level of the new and current products when operating with the same operating airflow.

At the estimated system impedance (equipment ventilation resistance) shown in the figure, the new product consumes 13% less power and produces 3 dB(A) less noise than the current product, demonstrating a higher efficiency and lower noise.

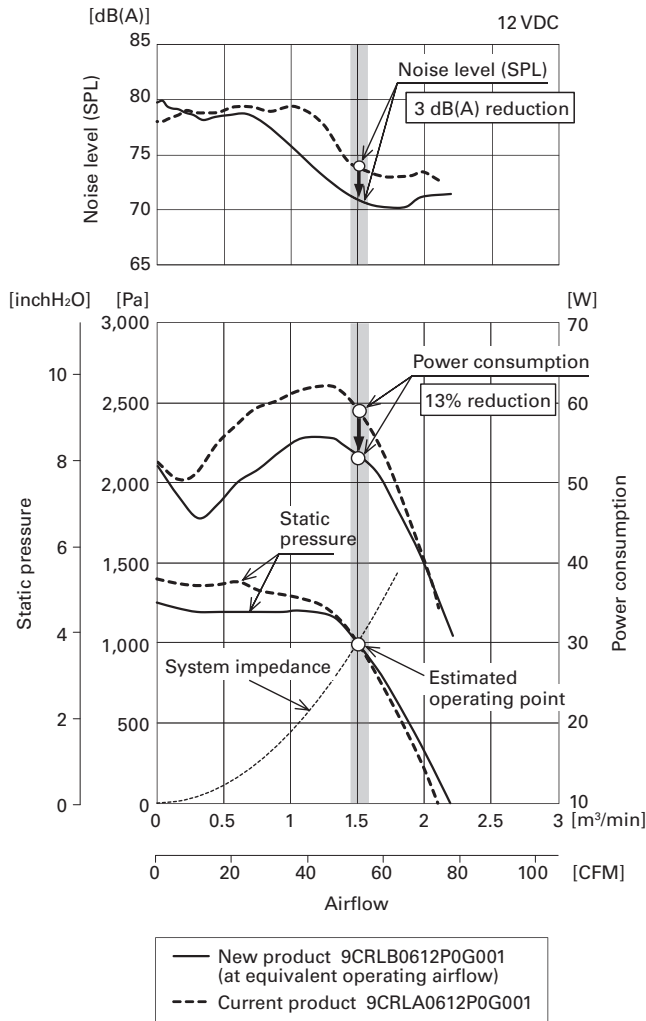

Fig. 8 Power consumption / Noise comparison between the new and current products

5.3 Environmental impact comparison

Figure 9 compares the CO₂ emissions of the new and current products over their life cycles.

Thanks to its greatly reduced power consumption, the new product emits 13% less CO₂ over its product life cycle compared to the current product. These improvements have qualified the new product for the Eco Products certification. Figure 10 shows the Eco Product symbol and logo.

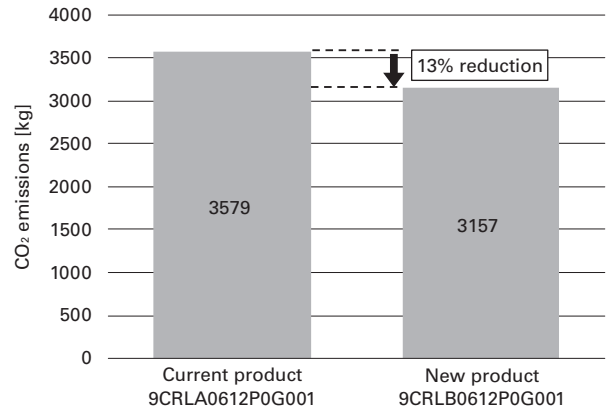

Fig. 9 CO₂ emissions comparison using our LCA calculation software (100,000 hours, when operating with the same operating airflow)



Fig. 10 Symbol and logo of Eco Products

6. Conclusion

This article introduced the features and performance of the *San Ace 60L 9CRLB* type Long Life Counter Rotating Fan.

The new product achieves higher airflow and static pressure than the current product while maintaining a long service life.

In addition, it achieves lower power consumption and lower noise under the same airflow. The product has been certified as an Eco Product due to the reduced environmental impact while maintaining the long service life of the current model.

We will continue to help our customers create new value by providing products that quickly address market demand.

Author

Naoya Inada

Design Dept., San Ace Company
Engages in the development and design of cooling fans.

Haruhisa Maruyama

Design Dept., San Ace Company
Engages in the development and design of cooling fans.

Haruka Sakai

Design Dept., San Ace Company
Engages in the development and design of cooling fans.

Koji Ono

Design Dept., San Ace Company
Engages in the development and design of cooling fans.

Honami Osawa

Design Dept., San Ace Company
Engages in the development and design of cooling fans.

60 × 60 × 56 mm *San Ace 60 9CRH* Type Counter Rotating Fan

Yukihiro Nagatsuka

Yen Junchieh

Louis Chen

Vincent Hsu

Noriaki Ogawa

Yusuke Okuda

Naohide Kamada

Shuta Yoshioka

Hiromitsu Kuribayashi

1. Introduction

With the development and growing demand of AI technology and ICT equipment, data centers and GPU servers are becoming increasingly crucial in supporting society and the economy. As equipment performance rapidly improves, so does the density and heat generation. Considering such market trends, many customers are adopting counter rotating fans, with a growing demand for fans that offer even higher cooling performance.

We previously developed and launched the 60 × 60 × 56 mm *San Ace 60 9CRA* type Counter Rotating Fan (hereinafter, “current product”). Now, in response to this market demand, we developed and launched the 60 × 60 × 56 mm *San Ace 60 9CRH* type Counter Rotating Fan (hereinafter, “new product”).

The new product features significantly reduced power consumption, qualifying for the Eco Products Plus certification, our new eco-design standard.

This article introduces the features and performance of the new product.

2. Product Features

Figure 1 shows the new product.

The new product delivers a higher airflow, higher static pressure, and lower power consumption while maintaining the same size as the current product.



Fig. 1 60 × 60 × 56 mm *San Ace 60 9CRH* type

3. Product Overview

3.1 Dimensions

Figure 2 shows the dimensions of the new product. It is designed to be compatible with the current product in dimensions and mounting.

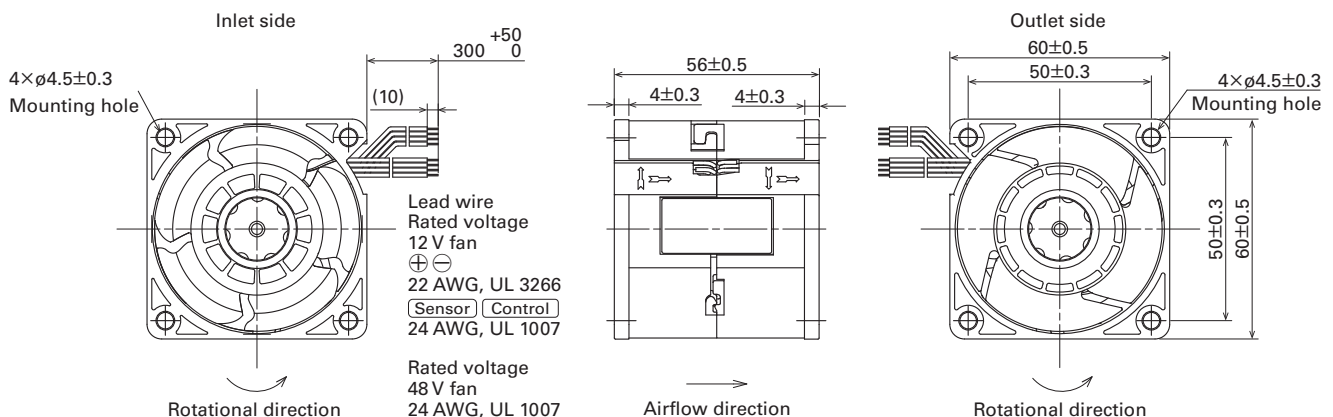

Fig. 2 Dimensions of 60 × 60 × 56 mm *San Ace 60 9CRH* type (Unit: mm)

Table 1 General specifications of 60 × 60 × 56 mm *San Ace 609CRH* type

Model no.	Rated voltage [V]	Operating voltage range [V]	PWM duty cycle* [%]	Rated current [A]	Rated input [W]	Rated speed [min^{-1}]		Max. airflow		Max. static pressure		Sound pressure level [dB(A)]	Operating temperature range [°C]	Expected life [h]		
						Inlet side	Outlet side	[m^3/min]	[CFM]	[Pa]	[inchH ₂ O]					
9CRH0612P6G001	12	10.8 to 13.2	100	5.6	67.2	26100	26800	2.57	90.8	3350	13.4	78	-20 to +70	40000 at 60°C (70000 at 40°C)		
			20	0.16	1.9	3900	4000	0.35	12.3	74	0.3				34	
9CRH0648P6G001	48	36 to 60	100	1.4	67.2	26100	26800	2.57	90.8	3350	13.4	78			-20 to +70	40000 at 60°C (70000 at 40°C)
			20	0.11	5.3	3900	4000	0.35	12.3	74	0.3					

Note : PWM input frequency is 25 kHz. Speed is 0 min^{-1} at 0% PWM duty cycle for models without ratings listed at 0%. The speed when control terminal is open is the same as when the PWM duty cycle is 100%.

3.2 Specifications

3.2.1 General specifications

Table 1 shows the general specifications of the new product.

3.2.2 Airflow vs. static pressure characteristics

Figure 3 shows the airflow vs. static pressure characteristics of the new product.

3.2.3 PWM control

The new product comes with PWM control for controlling fan speed.

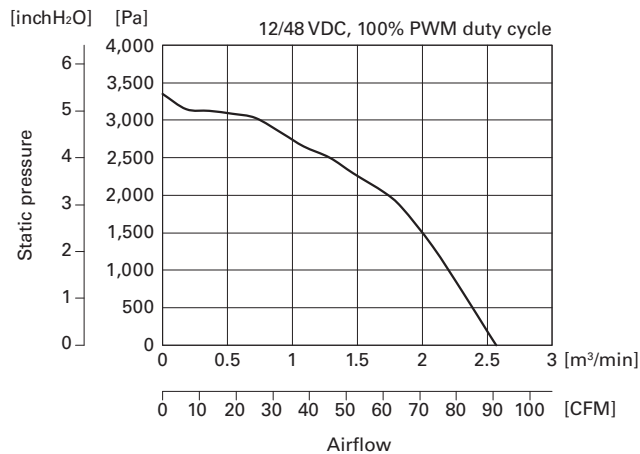

Fig. 3 Airflow vs. static pressure characteristics of the new product

4. Key Points of Development

The new product employs a highly efficient 3-phase drive motor, as well as newly designed impeller and frame shapes with high aerodynamic performance, achieving higher airflow, higher static pressure, and lower power consumption compared to the current product.

The key points of development are as follows.

4.1 Motor design

Achieving higher airflow and static pressure than the current product required a faster speed. To reduce power consumption, improving motor efficiency is essential. To achieve these, the new product uses a 3-phase drive motor, which is suitable for achieving both high speed and high efficiency, while a bipolar drive (single-phase full-wave) motor is used in the current product. These design improvements has resulted in higher airflow, increased static pressure, and lower power consumption.

4.2 Impeller and frame design

Figure 4 compares the fan blade shapes of the new and current products. Compared to the current product, the shape of the inlet fan blades has been redesigned significantly to adopt the shape of our 60 × 60 × 38 mm 9HVA type fan, which has a proven track record of high static pressure and low power consumption. The outlet fan blades have been revised to have a larger blade area than that of the current product. Also, we optimized the combination of inlet and outlet fans, ensuring high performance.

Besides the blade shape, the frame shape and fan speed are also key performance-determining factors of cooling fans. As this product is a Counter Rotating Fan, which involves two axial fans, finding the optimal combination was more challenging than normal with the number of parameters to consider being doubled. To identify the optimal combination in the shortest possible time, we conducted simulations alongside evaluation on actual equipment, successfully achieving high airflow, high static pressure, low power consumption, and low noise.



Fig. 4 Comparison of the impeller shape of the new and current products

Figure 5 compares the frame shapes at the frame joints of the new and current products.

A Counter Rotating Fan consists of two axial fans connected in series, and the current product has protruding flanges at the joint of the inlet and outlet fans. However, considering that today's equipment is becoming denser, it has been required to leave as much space as possible around the fan frame for part mounting and wiring purposes. To address this, we redesigned the frame fixing structure in the new product, and we eliminated the flanges and instead adopted embedded joint fixtures on the frame surface.

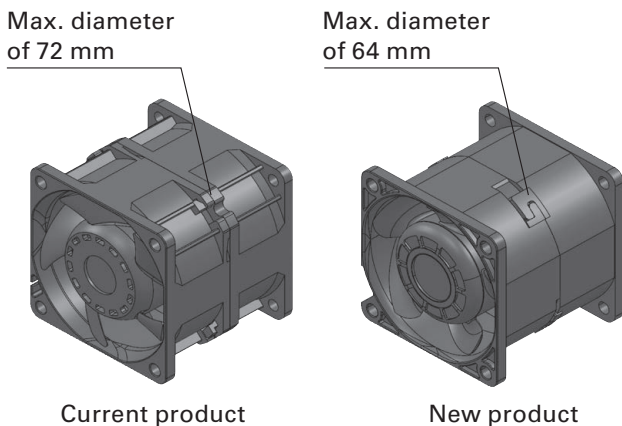

Fig. 5 Frame shape comparison at joint parts of the new and current products

By refining the shape of the joint fixtures, we ensured workability and strength while minimizing the protrusion on the frame. This maximized the space around the frame, resulting in a compact design that saves space when the fan is installed inside equipment.

5. Comparison of New and Current Products

5.1 Comparison of airflow vs. static pressure characteristics

Figure 6 compares the airflow vs. static pressure characteristics of the new and current products.

Compared to the current product, the maximum airflow and maximum static pressure of the new product have improved by 12% and 196%, respectively. This has resulted in high airflow and high static pressure.

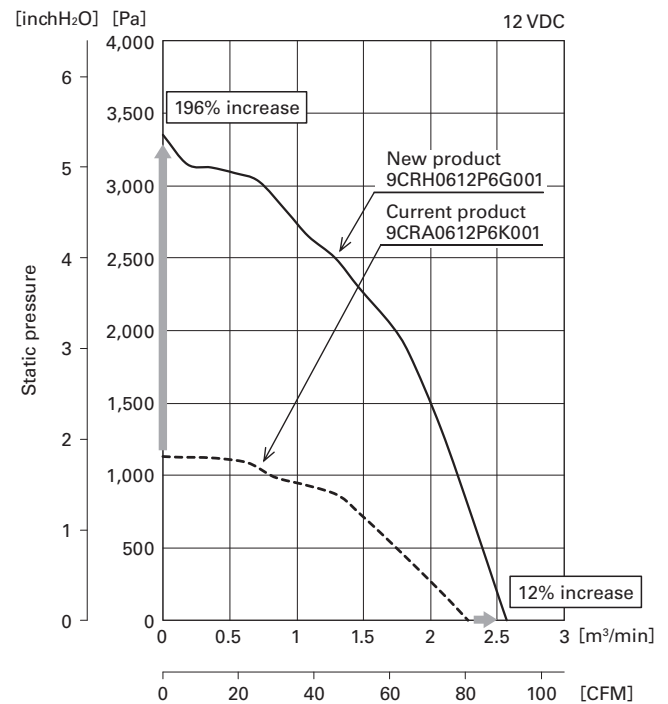

Fig. 6 Airflow vs. static pressure characteristics of the new and current products

5.2 Power consumption and noise comparison

Figure 7 compares the power consumption and noise level of the new and current products when operating with the same operating airflow.

At the estimated system impedance (equipment ventilation resistance) shown in the figure, the new product consumes 22% less power and produces 4 dB(A) less noise than the current product. This has resulted in a higher efficiency and lower noise.

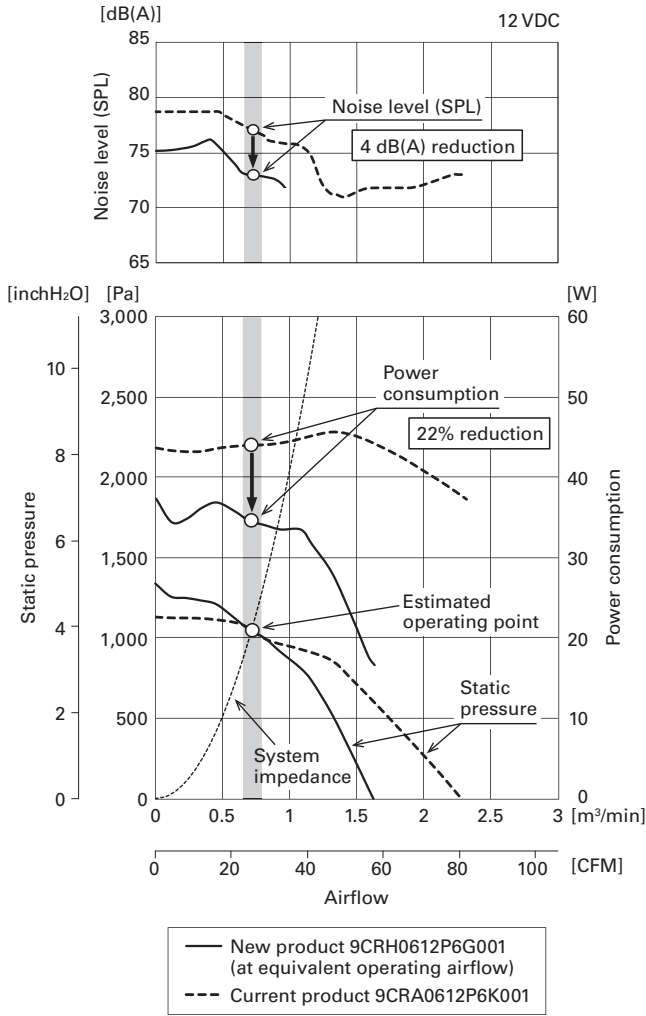

Fig. 7 Power consumption / Noise comparison between the new and current products

5.3 Comparison of inlet-outlet joint parts

As shown in Figure 5, the maximum diameter of the inlet-outlet joint has been reduced by 11% compared to the current product, from $\phi 72$ mm to $\phi 64$ mm.

5.4 Environmental impact comparison

Figure 8 compares the CO₂ emissions of the new and current products over their life cycles.

Thanks to its greatly reduced power consumption, the new product emits 22% less CO₂ over its product life cycle compared to the current product. This reduction was rated highly, leading to the new product being qualified as an Eco Product Plus. Figure 9 shows the Eco Product Plus symbol and logo.

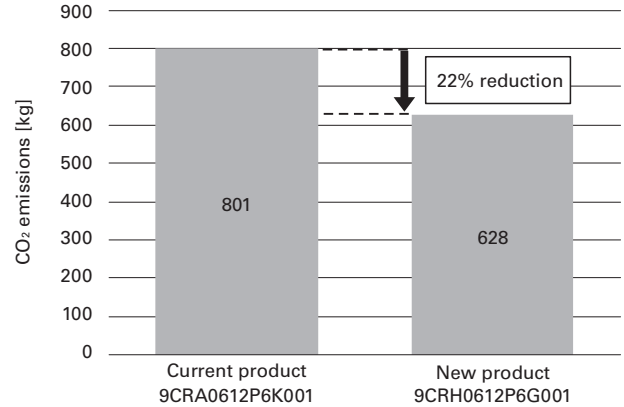

Fig. 8 CO₂ emissions comparison using our LCA calculation software (40,000 hours, when operating with the same operating airflow)



Fig. 9 Symbol and logo of Eco Products Plus

6. Conclusion

This article has introduced the features and performance of the newly developed 60 × 60 × 56 mm *San Ace 60 9CRH* type Counter Rotating Fan.

The new product delivers higher airflow and static pressure than the current product. Moreover, it achieves lower power consumption and lower noise at the same airflow. These parameters earned high scores in our assessment, earning the Eco Products Plus certification of the product. Moreover, the eliminated flanges at frame joints and reduced maximum diameter led to downsizing, giving it a higher degree of design freedom for customers when mounted in their equipment.

We will continue to help our customers create new value by swiftly meeting market demand and offering eco-friendly products.

Author

Yukihiro Nagatsuka

Design Dept., SANYO DENKI TAIWAN CO. LTD
Engages in the development and design of cooling fans.

Yen Junchieh

Design Dept., SANYO DENKI TAIWAN CO. LTD
Engages in the development and design of cooling fans.

Louis Chen

Design Dept., SANYO DENKI TAIWAN CO. LTD
Engages in the development and design of cooling fans.

Vincent Hsu

Design Dept., SANYO DENKI TAIWAN CO. LTD
Engages in the development and design of cooling fans.

Noriaki Ogawa

Design Dept., San Ace Company
Engages in the development and design of cooling fans.

Yusuke Okuda

Design Dept., San Ace Company
Engages in the development and design of cooling fans.

Naohide Kamada

Design Dept., San Ace Company
Engages in the development and design of cooling fans.

Shuta Yoshioka

Design Dept., San Ace Company
Engages in the development and design of cooling fans.

Hiromitsu Kuribayashi

Design Dept., San Ace Company
Engages in the development and design of cooling fans.

SANUPS Products and SDGs

Masayuki Shibata Hiroaki Sakata Hitoshi Kudo

1. Introduction

Based on our corporate philosophy to “aim to help all people achieve happiness, and work with people to make their dreams come true,” we have provided products and services that contribute to people’s happiness. This aligns closely with the sustainable and prosperous society envisioned in the Sustainable Development Goals (SDGs), a shared set of goals embraced by the global community.

Consistent with our corporate philosophy, we promote the following three to advance the SDGs.

- (1) Resolving social issues through businesses
- (2) Creating a fulfilling workplace
- (3) Sustainable manufacturing

This article will first explore how our SANUPS products contribute to addressing social challenges. We will then discuss how our product development and production technologies are related to these “creating a fulfilling workplace” and “sustainable manufacturing” while contributing to achieving the SDGs.

2. Resolving Social Issues through Businesses

Our SANUPS product lineup includes renewable energy inverters, UPSs (uninterruptible power supplies), and engine generators. Renewable energy inverters are devices that promote the use of renewable energy and protect the global environment. UPSs ensure a stable power supply, contributing to the protection of people’s health and safety.

We will first introduce the *SANUPS W83A* power conditioner, or renewable energy inverter, that supports various renewable energy sources. Next, we will introduce the *SANUPS A11N*, a highly reliable UPS capable of redundant operation, and the *SANUPS A11K-Li*, a UPS designed for high-peak current capability.

2.1 The *SANUPS W83A* renewable energy inverter⁽¹⁾

In recent years, the adoption of renewable energy sources has been expanding as part of efforts to realize a low-carbon society. Renewable energy sources include solar, wind, hydro, biomass, among others. Previously, it was necessary to select a renewable energy inverter tailored to each specific generation system. To solve this problem, we developed the *SANUPS W83A* renewable energy inverter, a single unit of which supports various renewable energy sources. Figure 1 shows the *SANUPS W83A*.



Fig. 1 The *SANUPS W83A* renewable energy inverter

The product provides optimal power control to match the customer’s generation system, from solar to wind, hydro, and biomass, thereby maximizing the renewable energy generation and increasing energy conversion efficiency. Compared to current products, it offers higher energy conversion efficiency and a more compact design. Consequently, it has been certified as an Eco

Product^(Note 1), meeting our own qualification standards for low environmental impact. By our product development, the *SANUPS W83A* contributes to protecting the global environment and realizing a low-carbon society.

Additionally, this product is capable of operating in both grid-connected and isolated modes. Its isolated operation mode enables the direct supply of renewable energy-generated power during emergencies such as power outages, supporting disaster management efforts and business continuity planning (BCP).

(Note 1) Our products are assessed over their life cycle for factors including product size, weight, power consumption, and CO₂ emissions, and those meeting our standards qualify as Eco Products.

2.2 The *SANUPS A11N* high-reliability parallel redundant UPS⁽²⁾

Today, our lives are surrounded by numerous electronic devices essential for protecting people’s safety, such as social infrastructure equipment, security systems, and devices for maintaining and managing the living environment. These devices have become indispensable, and their downtime can result in significant societal and economic impacts. The *SANUPS A11N* is a highly reliable UPS designed to maintain critical operations, allowing replacement of failed units without shutting down the system.

It is available in two types. The single unit type has a single 5 kVA base unit with AC output outlets on the back of the unit, while the parallel connection type comes with a power distribution unit and is scalable up to 20 kVA by combining up to four base units in parallel. Figure 2 shows the *SANUPS A11N* parallel connection type.

In parallel redundant operations, each unit independently controls voltage, frequency, and load sharing. As shown in Figure 3, even during parallel redundant operations, units can be replaced or expanded without shutting down the entire system, ensuring enhanced maintainability.

The *SANUPS A11N* secures a continuous and stable power supply, keeping vital equipment operational and contributing to people’s safety.

Additionally, the product has been certified as an Eco Product^(Note 1) due to its improved conversion efficiency compared to current products. This advancement supports CO₂ emission reductions and mitigates the product’s global environmental impact.



Fig. 2 The *SANUPS A11N* parallel model

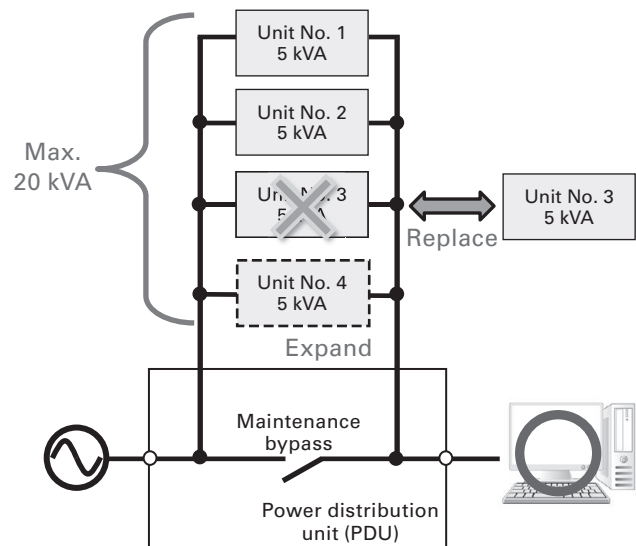

Replacement or expansion can be performed without interrupting power supply to the load.

Note: The load capacity does not include replaced or expanded units.

Fig. 3 Parallel redundant system

2.3 The *SANUPS A11K-Li* UPS, freezer-dedicated model⁽³⁾

The COVID-19 pandemic, caused by the novel coronavirus disease that emerged in 2019, profoundly impacted society worldwide. Ensuring proper temperature control for COVID-19 vaccines has been particularly challenging, as their freezers require a stable power supply. To address this need, the freezer-specific model of the *SANUPS A11K-Li*, a double conversion online UPS, was developed.

Figure 4 shows the product. This product features

improved peak current capability, enabling it to continue uninterrupted power supply even during sudden inrush currents caused by compressor start-ups. The product has successfully passed the combination test with ultra-low temperature freezers (deep freezers) designated by the Ministry of Health, Labour and Welfare.

Designed for convenience and reliability, this product is equipped with a NEMA 5-15P input power plug, allowing connection to standard wall AC outlets, and casters for easy mobility.

As a UPS tailored to vaccine freezers against COVID-19 and other diseases, the *SANUPS A11K-Li* reliably ensures public health.



Fig. 4 The *SANUPS A11K-Li* freezer-dedicated model

3. Creating a Fulfilling Workplace

As examples of creating fulfilling workplaces, we will highlight team activities and product development initiatives.

First, we will present five teams from the Electronics Company. Following that, we will introduce initiatives aimed at developing engineers using virtual simulators, as well as efforts to improve design and development capabilities through joint development with overseas R&D bases.

3.1 Five teams

In April 2024, SANYO DENKI introduced the business company system. As part of this reorganization, the former Power Systems Division and the amplifier/driver-related departments of the former Servo Systems Division were integrated into the newly established Electronics Company. Based on its philosophy of “creating joy for customers, fulfillment for employees, and inspiration for people,” the Electronics Company has launched the five-team initiative, illustrated in Figure 5.

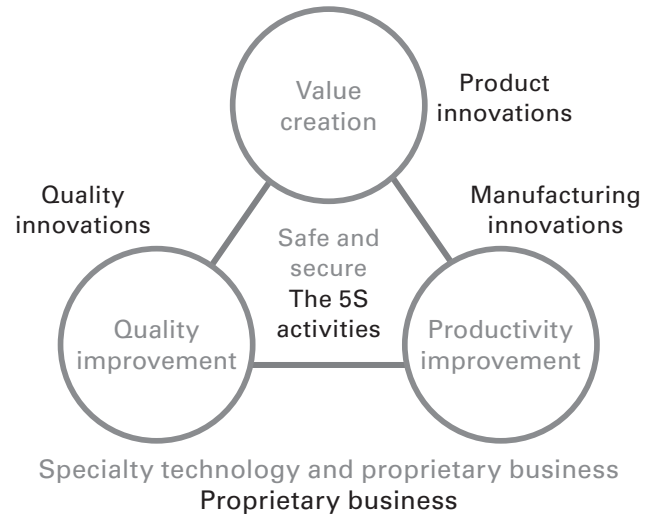

Five initiatives

1. Value creation:
Offer new value (products and services) for customers.
2. Quality improvement:
Provide “safe and secure” product quality.
3. Productivity improvement:
Increase productivity in manufacturing.
4. Safe and secure:
Create a safe, secure, and fulfilling workplace.
5. Proprietary business:
Create proprietary businesses leveraging our specialty technologies.

Fig. 5 How five initiatives and team activities are related

The objectives of the five teams are as follows.

- (1) **Product Innovations Team**
This team focuses on delivering new value (products and services) to customers by combining SANUPS’s power conversion, power storage, and power generation technologies with SANMOTION’s control technologies to create new, innovative technologies and products.
- (2) **Quality Innovations Team**
To ensure that customers can use products and services safely and reliably, this team will pursue advancements in quality.
- (3) **Manufacturing Innovations Team**
This team aims to maximize value while minimizing costs by increasing production efficiency through approaches such as consolidating and integrating production processes.
- (4) **5S Workplace Organization Team**
Through 5S (five S’s) Workplace Organization—Sort, Set in Order, Shine, Standardize, and Sustain—this team works to establish a safe, secure, and fulfilling

workplace. This foundation supports value creation, quality enhancement, manufacturing improvement, and human resource development.

(5) Proprietary Business Team

This team focuses on leveraging our specialty technologies to create proprietary businesses unique to the Electronics Company.

With the participation of all employee, these five teams set goals, plan specific initiatives, and work to create fulfilling workplaces.

3.2 Developing engineers proficient in virtual simulators

Conventional product development often involves repeated cycle of prototype development, evaluation, and improvement, which can be both costly and time-consuming. To tackle this problem, we established a development environment using the Virtual Product and Process Simulator (hereinafter, “VPS”). This tool employs three-dimensional data and enables evaluation within a virtual space.

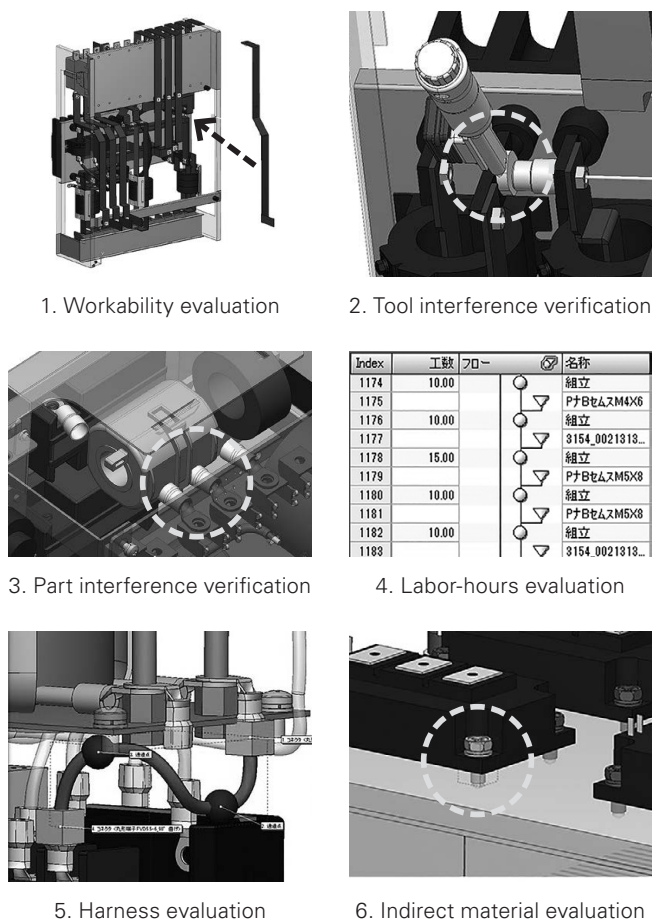

Fig. 6 Examples of evaluation performed in the VPS

Using the VPS, the production department can assess factors such as part and tool interference, assembly workability, and labor hours. By identifying and addressing issues in this virtual environment, the department has successfully reduced the number of prototype development and evaluation cycles. Figure 6 illustrates an example of evaluation performed in the VPS.

In addition to creating a three-dimensional data environment and establishing operational guidelines, we provided practical training to develop engineers skilled in evaluating product structures with the VPS. This initiative has enhanced the production department’s involvement in product development while fostering a more fulfilling workplace environment.

3.3 Joint development with SANYO DENKI PHILIPPINES

In 2019, SANYO DENKI PHILIPPINES, INC. (hereinafter, “SDP”) established a Technology Center as a R&D base for our group. Below, we introduce an example of cooperative customization development efforts for SANUPS products carried out at SDP.

Working with the SDP Design Department, we developed customizations such as modifications to UPS specifications and changes to parts. For modifications to UPS specifications, the SDP Design Department carried out the sheet metal design, input power cable design, and internal wiring verification. For changes in parts due to discontinued parts, SDP managed alternative parts selection, board design, and evaluation. With technical support from Japan and clear communication regarding work details, the design and evaluation process were successfully completed as planned.

By improving SDP’s design and development capabilities and jointly working on customization projects, we contributed to creating a fulfilling workplace within our group company. Looking ahead, we plan to expand our collaboration with SDP, focusing on the planning and development of both jointly created products and SDP’s original products.

4. Sustainable Manufacturing

As part of our sustainable manufacturing, we will introduce initiatives in production activities.

First, as an initiative in the production process, we will introduce an example in which we improved productivity by building automated assembly/inspection equipment for the *SANUPS LiB Pack*, a lithium-ion battery pack. Then, as an initiative at the production site, we will look at the recycling of solder generated during the production process.

4.1 Building automated assembly/ inspection equipment of the *SANUPS LiB Pack*

In recent years, the use of lithium-ion batteries in UPSs has risen due to their long lifespan and compact size. We have developed the *SANUPS LiB Pack* lithium-ion battery pack to further enhance power supply safety and stability. This product is certified as an Eco Product^(Note 1) and offers several advantages over lead-acid batteries of the same capacity, including a significantly longer service life, lighter weight, and reduced waste.

To minimize production costs for the *SANUPS LiB Pack*, we have built automated assembly/inspection equipment for key processes, including assembly, welding, and inspection, as shown in Figure 7.



Fig. 7 The *SANUPS LiB Pack* automated assembly/ inspection equipment

4.1.1 Optimized welding technique

The optimal welding of the *SANUPS LiB Pack* depends on three key factors: welding technique, material/shape, and welding conditions.

For the welding technique, resistance welding is selected for its cost-effectiveness, structural advantages, and suitability for welding thin plates, as shown in Figure 8. As for the material/shape, copper alloy was optimized in shape to achieve high-quality welding, as shown in Figure 9. For the welding conditions, the optimal combination of current, voltage, energization duration, and pressure application was identified along with threshold values for each parameter. These factors are constantly monitored by the automated assembly/inspection equipment, ensuring improved manufacturing quality.



Fig. 8 Resistance welding

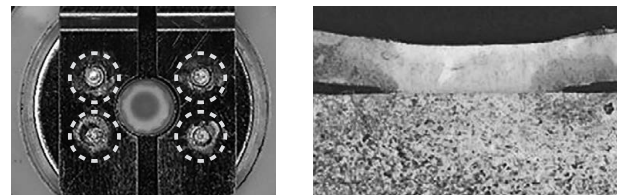

Fig. 9 Weld mark and cross-section

4.1.2 Quality control sharing between processes

The automated assembly/inspection equipment collects and integrates manufacturing and inspection data throughout the production process, from the acceptance inspection of the lithium-ion batteries used in the *SANUPS LiB Pack* to final assembly. This system enables seamless data sharing between processes and structures mechanisms to detect and reject uninspected or defective products, preventing them from advancing to the next stage of production.

4.1.3 Effects of the automated assembly/inspection equipment

The automated assembly/inspection equipment for the *SANUPS LiB Pack* has enabled significant reductions in lead time compared to using pre-manufactured lithium-ion batteries. In addition, thanks to the optimized welding technique and the quality control across processes, product quality and productivity have been improved.

4.2 Solder recycling

We have established an in-house solder recycling system for waste solder generated during the production process of printed circuit boards, or PCBs.

Previously, waste solder was outsourced to recycling and solder vendors, as shown in Figure 10. By establishing an in-house recycling system, we have eliminated the need for outsourcing. This system has enabled us to recycle and reuse approximately 640 kg of solder annually out of 1,000 kg of waste solder that previously sent to recycling vendors.

Conventional recycling workflow

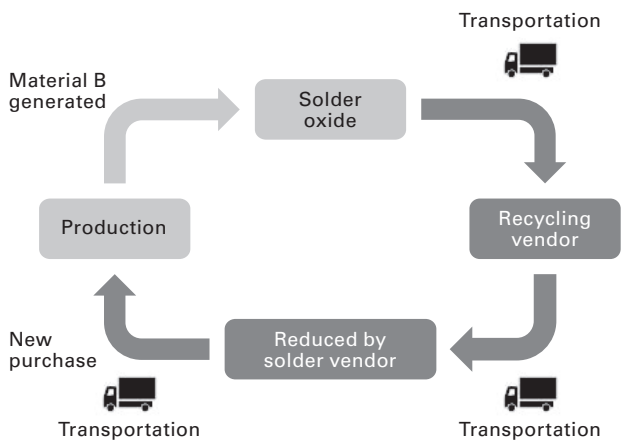

Current recycling workflow

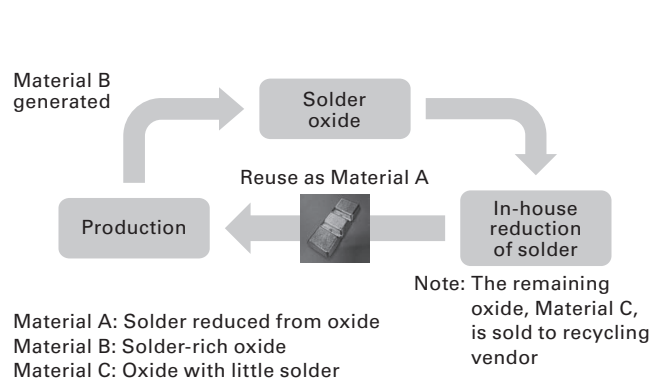

Fig. 10 Solder recycling workflow

In-house recycling of waste solder not only improves the sustainability of production and consumption but also reduces CO₂ emissions associated with transporting waste solder to external vendors, contributing to reducing the global environment impact.

5. Conclusion

This article outlined three key initiatives involving SANUPS products to help achieve the SDGs.

- (1) Resolving social issues through businesses
 - The *SANUPS W83A* renewable energy inverter contributes to protecting the global environment and realizing a low-carbon society.
 - The *SANUPS A11N* Online UPS ensures critical equipment remains operational with a continuous and stable power supply, protecting people’s safety.
 - The *SANUPS A11K-Li* Online UPS offers reliable power for vaccine freezers, protecting public health.
- (2) Creating a fulfilling workplace
 - With the participation of all employee, the five teams are working to create fulfilling workplaces.
 - By leveraging virtual simulators, the production department is also deeply involved in product development.
 - Our joint development efforts with SANYO DENKI PHILIPPINES have improved their design and development capabilities, contributing to creating a fulfilling workspace.

(3) Sustainable manufacturing

- The development of automated assembly/inspection equipment for the *SANUPS LiB Pack* lithium-ion battery pack has significantly improved productivity.
- Establishing an in-house solder recycling system has created internal recycling workflow, reducing environmental impact.

Demand for SANUPS products continues to grow. To meet this demand, we remain committed to developing SANUPS products that protect the global environment and people’s health and safety. Through product development and production activities, we will continue offering value to our customers and contributing to achieving a sustainable and prosperous society.

Reference

- (1) Takuya Ota and 12 others: “Development of the *SANUPS W83A* Grid-connected Isolated Type”
SANYO DENKI Technical Report No.58, pp.27-34 (2024.11)
- (2) Makoto Kitazawa and 7 others: “Development of the *SANUPS A11N* Online UPS”
SANYO DENKI Technical Report No.54, pp.29-35 (2022.11)
- (3) Naohiko Shiokawa: “Feature: Technical Developments in 2021”
Power Systems Division
SANYODENKI Technical Report. No.53, pp.17-18 (2022.5)

Author

Masayuki Shibata

Design Dept., Electronics Company
Engages in the development and design of power supplies units.

Hiroaki Sakata

Subsect. 1, Production Engineering Sect., Production Dept.,
Electronics Company
Engages in the production engineering of power supply units.

Hitoshi Kudo

Subsect. 2, Production Engineering Sect., Production Dept.,
Electronics Company
Engages in the production engineering of motion controllers and
servo amplifiers.

Development of the *SANUPS W83A* Renewable Energy Inverter

Takuya Ota Yuji Wada Takashi Kobayashi Makoto Ishida Tetsuya Fujimaki
 Sho Niimura Mika Takehara Katsutoshi Tanahashi Kiyoshi Mizuguchi Katsuhiro Yoshizawa
 Yutaka Kato Hironori Ogihara Noriyuki Kawashima

1. Introduction

In recent years, the adoption of renewable energy sources has been expanding as part of efforts to realize a low-carbon society, which increased demand for renewable energy inverters. There are multiple types of renewable energy sources such as solar, wind, hydro, and biomass, each of which requires renewable energy inverters capable of converting power specific to each source. There is also a growing demand for renewable energy inverters that can connect to storage batteries to balance power supply and demand.

In light of this market, we developed the *SANUPS W83A* renewable energy inverter that connects to various power generation systems and storage batteries and includes a built-in wireless communication.

This article provides an overview of the *SANUPS W83A* renewable energy inverter, highlighting its features and the key development points.

2. Product Overview

The *SANUPS W83A* is a 3-phase 3-wire, 202 VAC, 49.9 kW renewable energy inverter.

This product eliminates the need for a different type of renewable energy inverter for various generation systems. It supports various renewable energy sources including solar, wind, hydro, and biomass, and storage batteries.

Featuring isolated operation, it provides power generated from renewable energy sources or stored in batteries in emergencies such as power outages, serving for disaster management and business continuity planning (BCP) purposes.

Furthermore, the wireless communication feature allows

status monitoring and settings adjustment via mobile devices, greatly improving operability and maintainability. The product also features simplified design compared to the current product, with the display screen and operation buttons removed, as shown in Figure 1.



Fig. 1 The *SANUPS W83A*

Table 1 shows the electrical specifications of the *SANUPS W83A*. To ensure compatibility with various generation systems and storage batteries, the hardware and basic electrical specifications, including grid output and isolated output, have been standardized.

Table 1 Electrical specifications of the SANUPS W83A

Items		Model no.	W83A493S	
System		PV generation	Generator (Hydro, wind, biomass, etc.)	Storage battery
Control method		Maximum power point tracking control (MPPT control)	Generator power curve control	Schedule-based charge/discharge control
Output capacity		49.9 kW (power factor 0.95 to 1.0)		
Main circuit type		Self-commutated voltage type		
Switching method		High-frequency PWM		
Isolation method		Commercial frequency isolation		
Cooling system		Forced air cooling		
DC input	Rated voltage	300 VDC		—
	Maximum allowable input voltage	650 VDC		—
	Input operating voltage range	200 to 600 VDC		—
	Rated output range	270 to 600 VDC		—
Grid-connected output	No. of phases/wires	3-phase 3-wire		
	Rated voltage	202 VAC		
	Rated frequency	50/60 Hz		
	Rated output current	143 AAC		
	Output current harmonic distortion	Total current: 5% or less, individual harmonic order: 3% or less		
	Output power factor	0.95 or greater		
	Power factor setting range	0.8 to 1.0 (in increments of 0.01)		
	Efficiency	95% (As per the efficiency measurement method stated in JIC C 8961, at a power factor of 1.0)		
Isolated output	Rated output	50 kVA (at 1.0 load power factor)		
	No. of phases/wires	3-phase 3-wire		
	Rated voltage	202 VAC		
	Voltage regulation	Within $\pm 8\%$ of rated voltage		
	Rated frequency	50/60 Hz		
	Frequency regulation	Within ± 0.1 Hz of rated frequency		
	Output voltage harmonic distortion	At linear load: 5% or less		
	Load power factor fluctuation range	0.7 to 1.0 (lagging)		
	Overload capability	100% continuous		
	Switching to isolated operation	Automatic or manual		
Storage battery Input/Output	Input operating voltage range	—	260 to 600 VDC	
	Rated output range	—	270 to 600 VDC	
	Maximum charge power	—	49.9 kW	
	Maximum charge current	—	185 ADC	
	Charge voltage range	—	270 to 600 VDC (in 1 V increments)	
	Maximum discharge current	—	195 ADC	
Grid protection		Overvoltage (OVR), undervoltage (UVR), overfrequency (OFR), underfrequency (UFR), allowable frequency in parallel		
Islanding detection	Passive method	Voltage phase jump detection		
	Active method	Frequency feedback method with step injection (Step 3.2)		
Communication system	Wired LAN interface	Ethernet 10Base-T/100Base-TX/1000Base-T		
	Wireless LAN interface	As per IEEE 802.11 b/g/n, frequency: 2.4 GHz		
	Between units	RS-485 (Modbus RTU)		
	Between LIB panels	RS-485 (Modbus RTU)		
Acoustic noise		62 dB or less (1 m from front of UPS, A-weighting)		
Operating environment	Temperature	-10 to +50°C (Output is derated above 40°C)		
	Relative humidity	30 to 90% (non-condensing)		
	Altitude	2000 m max.		

3. Features

3.1 Support for various renewable energy sources and storage battery

Generally, as shown in Table 2, different power control methods are required depending on the connected application, including a PV cell, generator, and storage battery. Previously, our product lineup offered renewable energy inverters that supports a specific control method.

By standardizing the software processing for control and functions as well as switching between different power control methods, the product supports the three power control methods with a single unit.

This allows it, with a single unit, to be used with various renewable energy generation systems and storage batteries by simply selecting the right power control method.

Table 2 Power control method and power usage

Generation system	Power control
PV cell	MPPT control
Generator (Hydro, wind, biomass, etc.)	Generator power curve control
Storage battery	Schedule-based charge/discharge control

3.1.1 Maximum power point tracking (MPPT^(note 1)) control

When connected to PV cells, the renewable energy inverter uses MPPT control to optimize power generation.

As shown in Figure 2, this control method adjusts the operating voltage to track the maximum power point^(note 2), thereby maximizing the use of PV cell power, which fluctuates with seasonal changes, weather conditions, and installation location.

(note 1) MPPT (Maximum Power Point Tracking)

(note 2) A control method that adjusts the operating voltage to maintain the optimal operating point, ensuring maximum power generation. When generated power increases, the operating voltage is adjusted in the same direction; when generated power decreases, it is adjusted in the opposite direction.

3.1.2 Generator power curve control

The generator power curve control method is used when a generator is connected to the renewable energy inverter. This method configures the input voltage and input power characteristics (generator power curve) to align with the generator's output characteristics, allowing operation at its most efficient point.

Figure 3 shows that two to 16 points on the power curve

can be set as desired, supporting various generators with a different output characteristics.

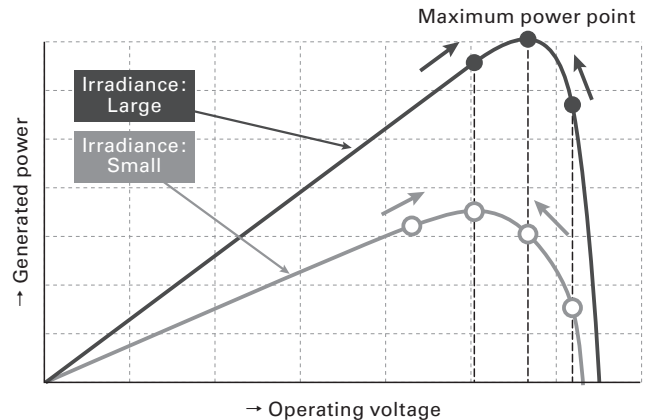

Fig. 2 MPPT control illustrated

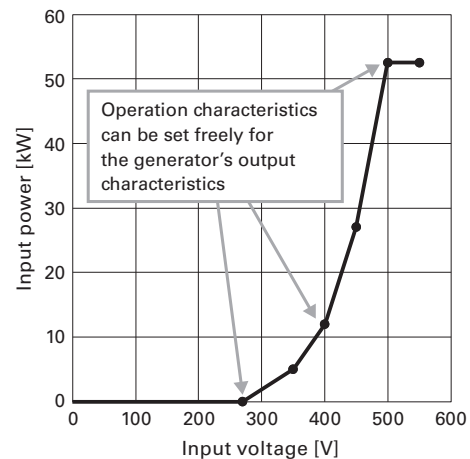

Fig. 3 Generator power curve settings illustrated

3.1.3 Schedule-based charge/discharge control

Schedule-based charge/discharge control is used when the renewable energy inverter is connected to a battery.

As shown in Figure 4, this method manages daily charge and discharge operations by configuring power levels for specific time intervals and allocating charge/discharge amounts according to a predefined schedule.

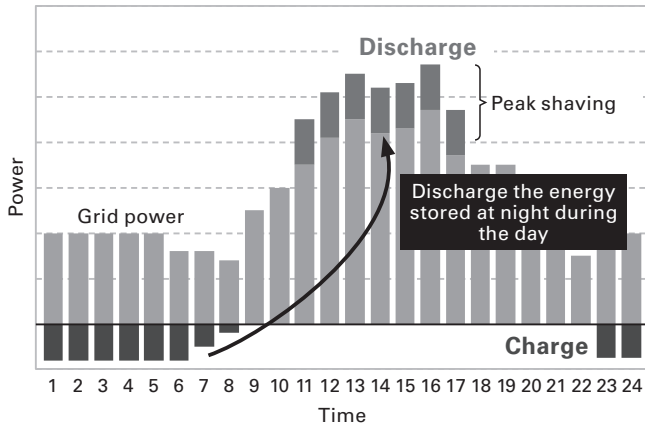

Fig. 4 Schedule-based charge/discharge control illustrated

For example, power can be stored in the battery during the night and supplied during the day when power demand peaks, effectively reducing grid power consumption during high-demand periods. This peak shaving control not only reduces grid power consumption but also helps stabilize power infrastructure during times of unmet power demand.

3.2 Disaster management and BCP measures

As mentioned above, the product features an isolated operation that supplies power during emergencies such as power outages. In isolated operation, it outputs AC power with constant voltage and frequency to a system different from the normal grid-connected output, powering emergency equipment and more. Even in isolated operation, this product can output a maximum of 50 kVA with 3-phase 3-wire 202 VAC.

This feature can contribute to disaster management and BCP (business continuity planning) purposes.

3.3 High efficiency

By using 2-phase modulation^(note 3) as the inverter control, switching losses have been reduced by a third. With this method, efficiency has been improved by 2.0% compared to our conventional product (the *SANUPS P73L*⁽¹⁾ PV inverter, 50 kW model), achieving a conversion efficiency of 95%.

This suppresses power consumption and heat generation, contributing to reducing CO₂ emissions. Of our products, those with sufficient energy-efficiency and environmental performance are assessed and certified as Eco Products^(note 4) or Eco Products Plus,^(note 4) and this product has been certified as an Eco Product.

(note 3) A modulation method in which only one of the three phases, closest to the peak value of the waveform, is fixed to ON or OFF at approximately one-sixth of the cycle of the reference waveform. The other two phases are modulated to complement the fixed phase.

(note 4) Our products are assessed over their life cycle for factors including product size, weight, power consumption, and CO₂ emissions, and those meeting our standards and higher standards qualify as Eco Products and Eco Products Plus, respectively.

3.4 Compatible with new grid-connection regulations

To connect (interconnect) a renewable energy inverter to a power company's power grid, permission must be obtained through consultation with the power company in accordance with the Grid-Interconnection Code.

This product now meets the following two new technical requirements.

3.4.1 Frequency feedback method with step injection (Step 3.2)^(note 5)

In the event of a power outage, renewable energy inverters must stop output and immediately disconnect from the grid as specified by the Grid-Interconnection Code. However, when multiple renewable energy inverters are installed, detection delays may occur due to interference. This product employs a method that instantly detects power outages and reliably stops output, even when multiple renewable energy inverters are installed. Starting in April 2024, power generating equipment with low-voltage interconnection is required to support this method, ensuring the product remains compliant and reliable.

(note 5) In the active islanding detection method, reactive power is injected based on the frequency deviation that occurs during a power outage. This process amplifies changes in the AC voltage frequency, allowing for quick and reliable detection of the outage.

3.4.2 Allowable frequency in parallel detection function^(note 6)

When the grid voltage or frequency deviates from the operating range, the renewable energy inverter goes into standby mode (parallel off from the grid). Once the grid voltage or frequency returns within the operating range, the renewable energy inverter reconnects to the grid (in parallel with the grid) and resumes operation.

However, if operation resumes while the grid frequency is near the upper limit of the operating range, the frequency may increase further, causing repeated cycles of operation and standby. This can lead to fluctuations in the grid frequency. To address this, this product is equipped with a function that resumes operation only after the grid frequency

is within an appropriate range, improving grid stability.

This function is already required for power generation equipment connected to extra-high-voltage grids. From 2025, it will also be required for equipment connected to high- and low-voltage grids.

(note 6) A technical requirement that allows power generating equipment to operate in parallel (connected to the grid power) when the grid frequency is below the allowable frequency for parallel operation (standard frequency +0.1 Hz).

3.5 Wireless communication for improved operability and maintainability

In the previous products, status monitoring and setting changes were carried out using a display screen and operation buttons located on the front of the unit. This product is equipped with wireless communication functions.

As shown in Figure 5, users can monitor the unit status and change settings remotely using a mobile device. The interface provides user-friendly screens including diagrams and graphs, improving operability.

Additionally, by connecting multiple renewable energy inverters via RS-485 communication, up to 10 inverters can be centrally controlled by a single mobile device.

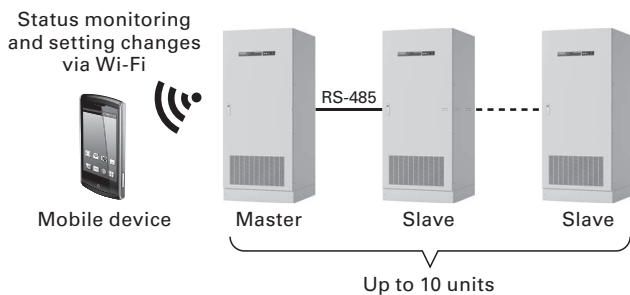

Fig. 5 Illustrative image of the connection between a mobile device and the SANUPS W83A

The wireless communication feature of this product was a result of combining the SANUPS LAN Interface Card⁽²⁾ and the SANMOTION Wireless Adapter 3A⁽³⁾. Both being our products, communication with high availability and stability can be provided for an extended period of time.

The following sections describe the operation panel.

3.5.1 Dashboard screen

Our conventional products offered an LCD screen that displays only numerical values, such as the power status of the renewable energy inverter. As shown in Figure 6, this product goes beyond numerical displays by visually showing power flow using animations, allowing users to check the

power and operating status of the entire system at a glance.

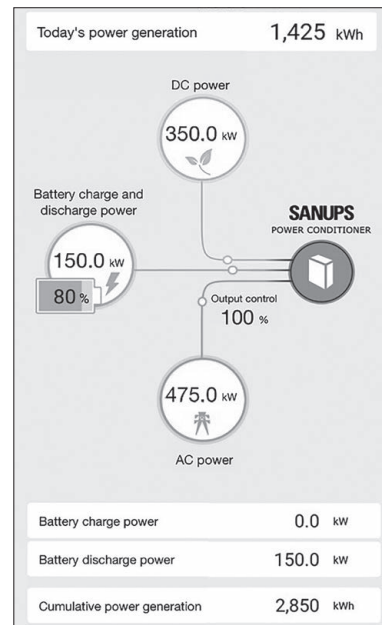

Fig. 6 Dashboard screen

3.5.2 Unit management screen

In the previous product, users had to check the LED lamps or LCD screen on each unit individually to verify the operating status of renewable energy inverters. Furthermore, the amount of measurement information displayed on a single LCD screen was limited.

With this product, as shown in Figure 7, the operating status is displayed on a mobile device in a convenient list format that includes details such as unit type and model number.

Device No.	Type/Model	Status
1	☀️ W83A493	Running ...
2	🌿 W83A493	Running ...
3	🏠 W83A493	Running ...
4	☀️ W83A493	Running ...
5	🌿 W83A493	Standby ...
6	🏠 W83A493	Standby ...
7	☀️ W83A493	Standby ...
8	🌿 W83A493	Stopped ...
9	🏠 W83A493	Stopped ...
10	☀️ W83A493	Stopped ...

Fig. 7 Unit list screen

As shown in Figure 8, users can view not only unit information and measurement values but also unit statuses and alarms by scrolling through the unit status and

measurement data screen.

This feature allows a large amount of information to be easily reviewed at a glance.

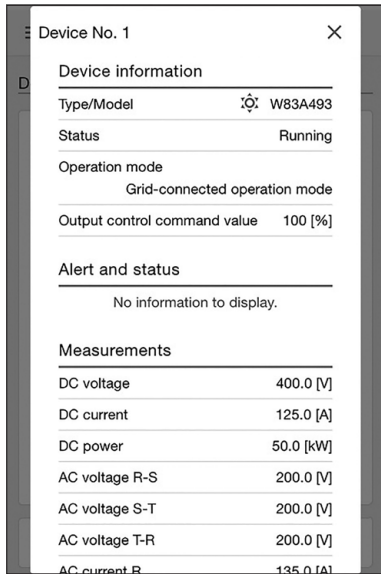

Fig. 8 Unit status and measurement data screen

In addition, as shown in Figure 9, multiple units can be started/stopped directly from the unit list screen, improving convenience.

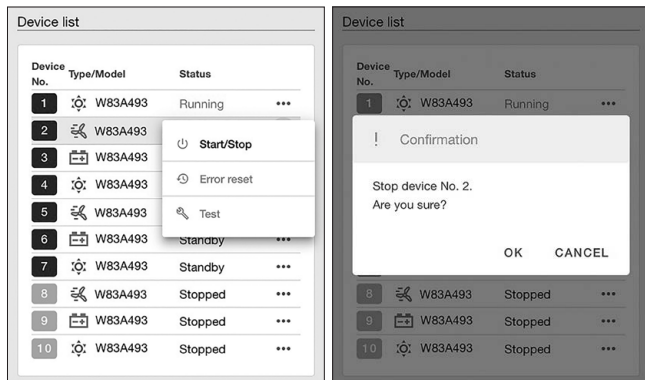

Fig. 9 Unit start/stop operation screen

3.5.3 Event log screen

With the conventional product, the unit status and alarm history used to be checked using on-unit buttons to select and display one entry at a time. In contrast, as shown in Figure 10, this product provides the entire unit status history in chronological order.

This feature enables users to review multiple event logs at once, simplifying unit management and recovery work.

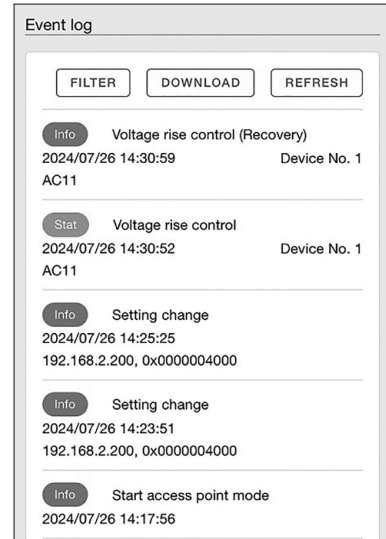

Fig. 10 Event log screen

3.5.4 Generator power curve setting screen

As shown in Figure 11, a generator's power curve is displayed in a graph by voltage and power values. This feature improves work efficiency by allowing users to configure numerical values directly while reviewing multiple settings simultaneously.

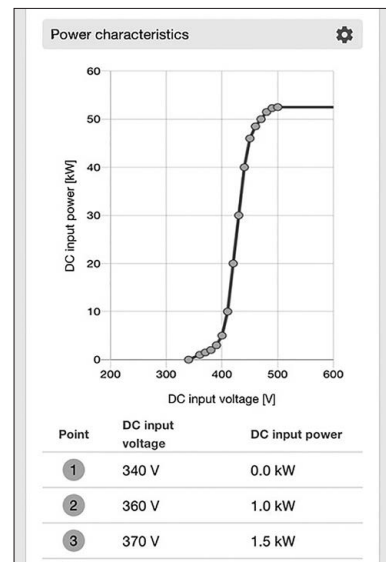

Fig. 11 Generator power curve setting screen

3.5.5 Charge/Discharge schedule setting screen

As shown in Figure 12, when using a storage battery, the charge/discharge schedule is visually displayed in a color-coded 24-hour pie chart. This makes it easy to configure and check the schedule, improving usability.

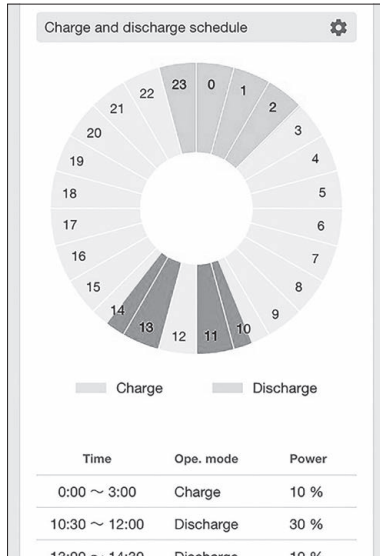

Fig. 12 Charge/Discharge schedule setting screen

3.6 Output control and remote monitoring

Maintaining a balance between power demand and generated power is important for providing a stable power supply. Power companies require renewable energy generation systems to control output, and renewable energy inverter must adjust their output based on the information from power companies.

To this end, our conventional products had to use an optional *SANUPS PV Monitor*⁽⁴⁾ or a mobile communication pack to access a power company's server for output control.

However, as shown in Figure 13, the *SANUPS W83A* supports output control via a wired LAN, enabling output control and remote control without requiring the options.

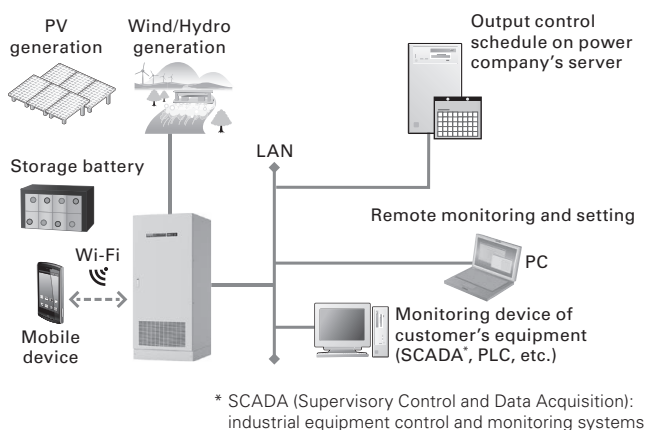

Fig. 13 The *SANUPS W83A* system configuration example

4. Conclusion

This article introduced the *SANUPS W83A* renewable energy inverter, highlighting its key features:

- (1) It supports power generation from various renewable energy sources, such as solar, wind, hydro, biomass, and waste heat by simply switching the settings, and can also be used in combination with a storage battery.
- (2) It features an isolated operation function that can supply power during emergencies such as power outages, contributing to disaster management and BCP purposes.
- (3) Switching losses have been reduced by one third, and efficiency has been improved by 2.0% compared to the conventional product. This reduces power consumption and heat generation, helping lower CO₂ emissions.
- (4) It complies with the new Grid-Interconnection Code.
 - Frequency feedback method with step injection (Step 3.2)
 - Detection function for allowable frequency in parallel
The product is suitable for power generating equipment interconnected to grids at extra-high, high, or low voltages.
- (5) It supports wireless communication and is compatible with mobile devices, allowing status monitoring and setting changes on intuitive screens. It also supports LAN network systems, enabling remote monitoring.

The *SANUPS W83A* is a product that greatly contributes to the realization of a low-carbon society. We will continue to help protect the environment and work toward a sustainable society by offering highly efficient products and services that help make better use of energy.

Reference

- (1) Tetsuya Fujimaki and 6 others: "Development of the *SANUPS P73L* PV Inverter with a Peak Cut Function" SANYO DENKI Technical Report, No. 44, pp. 34-42 (2017.11)
- (2) Katsuhiro Yoshizawa and 6 others: "Development of 1-Gigabit Ethernet LAN Interface Card for UPSs" SANYO DENKI Technical Report, No. 55, pp. 18-23 (2023.5)
- (3) Shigeki Sato and 5 others: "Development of *SANMOTION C Wireless Adapter 3A*," SANYO DENKI Technical Report, No. 50, pp. 35-38 (2020.11)
- (4) Naoki Takemoto and 3 others: "Development of the *SANUPS PV Monitor E Model* with an Output Control Function" SANYO DENKI Technical Report, No. 41, pp. 28-33 (2016.5)

Note: The company names and product names listed in this document are the trademarks or registered trademarks of their respective owners.

Author

Takuya Ota

Design Dept., Electronics Company
Engages in the development and design of power supply units.

Yuji Wada

Design Dept., Electronics Company
Engages in the development and design of power supply units.

Takashi Kobayashi

Design Dept., Electronics Company
Engages in the development and design of power supply units.

Makoto Ishida

Design Dept., Electronics Company
Engages in the development and design of power supply units.

Tetsuya Fujimaki

Design Dept., Electronics Company
Engages in the development and design of power supply units.

Sho Niimura

Design Dept., Electronics Company
Engages in the development and design of power supply units.

Mika Takehara

Design Dept., Electronics Company
Engages in the development and design of power supply units.

Katsutoshi Tanahashi

Design Dept., Electronics Company
Engages in the structural design of power supply units.

Kiyoshi Mizuguchi

Design Dept., Electronics Company
Engaged in the development and design of power supply units and monitoring devices.

Katsuhiko Yoshizawa

Design Dept., Electronics Company
Engaged in the development and design of power supply units and monitoring devices.

Yutaka Kato

Design Dept., Electronics Company
Engaged in the development and design of power supply units and monitoring devices.

Hironori Ogihara

Design Dept., Electronics Company
Engaged in the development and design of power supply units and monitoring devices.

Noriyuki Kawashima

Design Dept., Electronics Company
Engaged in the development and design of power supply units and monitoring devices.

SANMOTION Products and SDGs

Naohiro Ito Koji Nakatake Takahiro Yoneta

1. Introduction

With growing interest in the SDGs (Sustainable Development Goals), initiatives and products supporting these goals are receiving increasing attention.

The “sustainable and prosperous society” envisioned by the SDGs aligns with our corporate philosophy of creating society where “we help all people achieve happiness.” Fulfilling this philosophy leads to the achievement of the SDGs.

This article presents cases of SANMOTION product proposals to customers, as well as our product development and production activities. These initiatives, guided by our corporate philosophy, demonstrate how we contribute to achieving the SDGs.

2. Resolving Social Issues through Businesses

One of the SDGs goal to “end hunger, achieve food security and improved nutrition and promote sustainable agriculture” identifies stable food supplies and sustainable agriculture as critical social issues.

This chapter presents an example where SANMOTION products were proposed for agricultural equipment use as a way to help address these social issues.

2.1 Proposal for broccoli harvesting robots

Agriculture requires constant human management such as cultivating crops, harvesting, and maintaining farmland.

However, in Japan, the aging agricultural workforce and declining population involved in agriculture makes it increasingly difficult to secure sufficient labor.

For this reason, automation and enhanced efficiency in agricultural work is becoming essential. To support this transformation, we are actively promoting SANMOTION products for agricultural equipment.

The rising production and consumption of broccoli have

created a demand to reduce the labor-intensive process of harvesting the crop manually. To address this need, we propose SANMOTION products in equipment designed to automatically harvest broccoli.

Figure 1 shows a broccoli harvesting robot operating in a field. These robots automatically navigate fields, use image recognition to identify harvestable broccoli, and automatically harvest the crops.

For the traveling axis of this broccoli harvesting robot, we proposed the 100 mm sq., 1.5 kW AC servo motor and the 50 A EtherCAT type AC servo amplifier from our *SANMOTION G* AC servo systems.

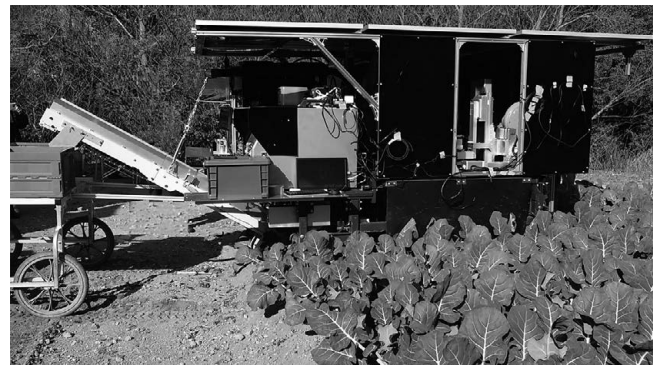

Fig. 1 Broccoli harvesting robot

The *SANMOTION G* servo systems, which feature compactness, light weight, and high efficiency, have been widely used by customers since its launch in 2022.

The *SANMOTION G* servo systems are certified as Eco Products under our own standards due to their low environmental impact and contribution to energy conservation. In addition, it was also honorably awarded the Good Design Award 2023.

The *SANMOTION G* motors are 20% shorter in length and 34% lighter compared to our conventional products. These improvements, along with enhanced performance and efficiency, have been well-received by customers.

The compact size allows for a smaller drive mechanism,

creating more space for harvested crops at the bottom of the machine. In addition, the lighter and more efficient servo motor and servo amplifier reduce the overall weight of the machine in motion, enhancing energy efficiency for the entire system.

We will remain committed to addressing social issues by promoting our products in the agricultural equipment market and advancing automation and labor efficiency.

Our domestic production and development facilities in Nagano—including Kangawa Works, Fujiyama Works, and the Technology Center—position us to support sustainable farming practices and address the declining number of successors in agriculture, contributing to the local community.

3. Creation of a Fulfilling Workplace and Product Development Combining Personnel Training

The SDGs to “promote sustained, inclusive and sustainable economic growth, full and productive employment and decent work for all” emphasizes the importance of fulfilling workplaces and initiatives that drive economic growth.

This chapter highlights initiatives that align with this goal of creation of motivating workplaces and product development combined with personnel training. It includes the Technology Center’s new wing, our joint development efforts with the Design Department of SANYO DENKI PHILIPPINES, INC. (SDP), and a case study on simulation technology.

3.1 Making more use of Technology Center’s new wing

In 2021, the new wing of the Technology Center began operations with the aim of improving productivity in design and development. The new wing is equipped with new facilities such as a 10-m method anechoic chamber, a vibration testing lab, and a durability testing lab with sound barriers. These have expanded our design room and laboratory space, which serves as the foundation for design and development.

Creating the spacious design and evaluation environment equipped with high-performance facilities, our designers are highly focused and motivated in their development efforts.

This section presents an example of the use of the 10-m method anechoic chamber, which contributes to reducing radiated emission levels.

High-precision, high-frequency parts often increase radiated emission levels, which we previously managed

through PCB near magnetic field analysis and pattern layout redesign.

With the new chamber, we can now perform 10-m method tests in-house, replicating certification tests by third-party bodies. This allows accurate measurement of radiated emission levels to confirm that they are within the limit prior to certification tests, avoiding the need for rework.

Figure 2 shows radiated emissions measured in the anechoic chamber of the Technology Center’s new wing during the development of the *SANMOTION G* servo amplifiers. The results demonstrate a significant reduction in high-frequency radiated emissions caused by reference clock signals, such as oscillators, compared to the previous product. The use of this facility also shortened the evaluation period.

The advanced facilities of the new wing, including the anechoic chamber, enhance productivity and innovation in design and development. By leveraging these facilities effectively, we aim to accelerate sustainable industrialization and foster ongoing innovation.

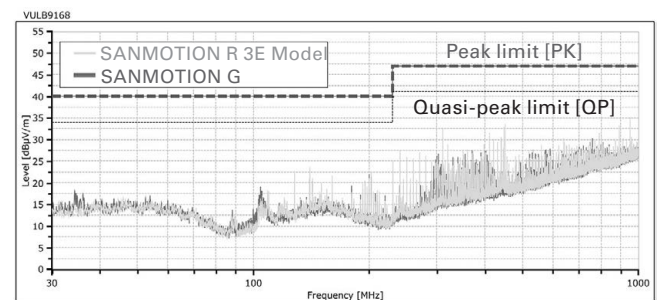

Fig. 2 Radiated emissions (10-m method, horizontal axis)

3.2 Joint development with SDP Design Department

To advance global design and competitiveness of our products, the SDP Design Department has been engaged in the design and development of SANMOTION products.

Since 2018, the team within the SDP Design Department that deals with SANMOTION products has contributed to design activities such as creating stepping motor drawings and providing technical support for mass production.

With the 9th Medium-term Management Plan launched in 2021, the SDP Design Department has focused on human resource development and improving evaluation environments in preparation of full-scale development work.

In 2022, an engineer from the SDP Design Department underwent a year of practical training at our Technology Center, gaining product knowledge, design technology, development processes, and evaluation methods for AC

servo amplifiers.

Figure 3 shows the servo amplifier evaluation testing process at the SDP Design Department. As a result of personnel training and the improved environment, the SDP Design Department is now capable of developing servo amplifiers.

In 2023, joint development efforts reduced the development period for expanding the *SANMOTION G* AC servo amplifier lineup by 2.5 months.



Fig. 3 Servo amplifier evaluation test at SDP Design Dept.

These initiatives not only enhance the skills and motivation of engineers in the Philippines but also improve product development capabilities and design productivity of the entire Group. Additionally, they contribute to promoting diversity, aligning with the goals of the SDGs.

3.3 Cases leveraging simulation technology

Previously, product development involved creating prototypes, evaluating them, and addressing any issues based on test results.

In recent years, designers have gained more autonomy to adopt new methods and technologies, applying trial and error to integrate them into practical product development.

These allow designers to use simulations to verify and predict design outcomes before prototypes are created, reducing rework, improving quality, and shortening development time.

Simulation technology has also proved very helpful in improving designers' skills. Comparing simulated predictions with actual results helps identify problems, analyze the causes, and propose solutions effectively.

This section showcases model base development, which serves as a case study on leveraging the simulation

technology that we have cultivated up to this point.

3.3.1 Model base development

We adopted model base development to optimize control systems for the *SANMOTION G* servo amplifier. This process involves creating a model^(note 1) of a servo motor or servo amplifier, simulating movements, and verifying performance before proceeding to product development, thereby further increasing efficiency.

3.3.2 Product development leveraging model base development

The process flow of model base development is illustrated in Figure 4.

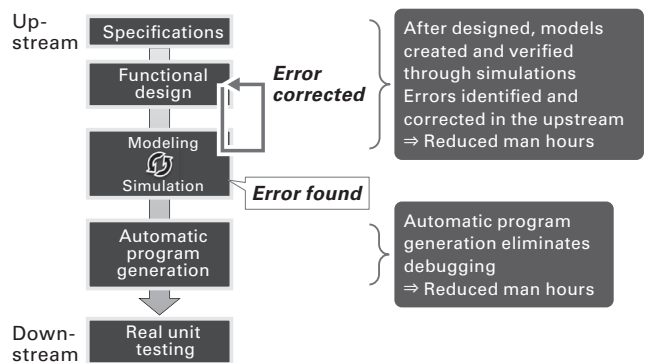

Fig. 4 Model base development workflow

The development steps are as follows.

- 1) Determine the product specifications.
- 2) Generate a functional design based on the specifications.
- 3) Create a model from the functional design (see Figure 5).
- 4) Check if the model complies with the coding guidelines and correct it (see Figure 5).
- 5) Validate model movements through simulations and fix errors (see Figure 5).
- 6) If results don't meet specifications, refine the functional design and finalize the model (see Figure 5).
- 7) Automatically generate the program from the finalized model and implement it on the actual product (see Figure 6).
- 8) Evaluate and validate the actual product.

(note 1) A "model" refers to a simplified block diagram for a subject system.

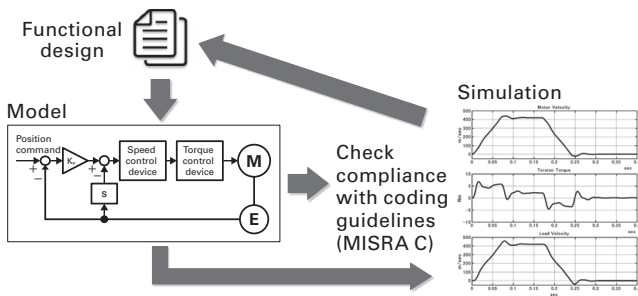

Fig. 5 Modeling and feedback of simulation results

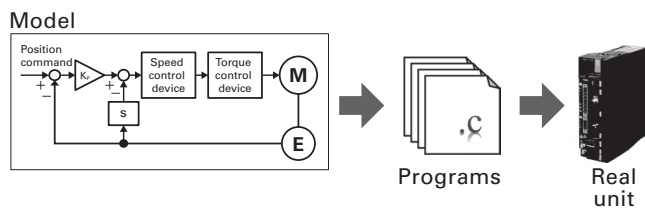

Fig. 6 Automatic program generation

This development method provides the following benefits:

- Verifications in the upstream process of development prevent errors from occurring in downstream.
- Automatic program generation eliminates human errors.
- Makes compliance with coding guidelines easy (MISRA C^(note 2)).
- Simulations allow unrestricted verification.

By adopting this model base development approach, we aim to significantly shorten development periods and improve product quality compared to conventional development methods.

We also addressed the heat generation issue in servo amplifiers by introducing thermal simulations. During the expansion of the *SANMOTION G* servo amplifier lineup, we optimized the heat dissipation design and adjust the cooling fan angle using simulations, promptly resolving the issue.

In the future, we will expand the application of model base development to include motion control systems in addition to servo control systems, while further enhancing product quality and development efficiency. Through these initiatives, we aim to motivate ourselves, advance our technologies, and contribute to higher levels of economic productivity, aligning with the goals of the SDGs.

(note 2) MISRA C: Guidelines For The Use of The C Language in Critical Systems

4. Sustainable Manufacturing

To “build resilient infrastructure, promote inclusive and sustainable industrialization and foster innovation” as outlined in the SDGs, we are committed to automating production lines and introducing systems that improve production efficiency. By consistently providing SANMOTION products that benefit society, we contribute to creation of a sustainable society.

This chapter presents our specific sustainable manufacturing initiatives for production systems and automated lines.

4.1 System for increasing production efficiency

4.1.1 Introduction of production guidance system

We employ production guidance systems in our manufacturing processes. Production guidance systems aim to standardize operations by displaying work procedures in digital format for operators, as shown in Figure 7. These systems enable efficient, error-free work and help stabilize quality and reduce resource waste, regardless of the operators’ skill level.

Furthermore, these systems allow inexperienced workers to quickly learn the operations, significantly shortening training periods.

The stored operation history in the database can be analyzed to identify time-consuming or complex processes, supporting quality improvement activities. These include enhancing work efficiency and reducing defect rates by preventing errors.

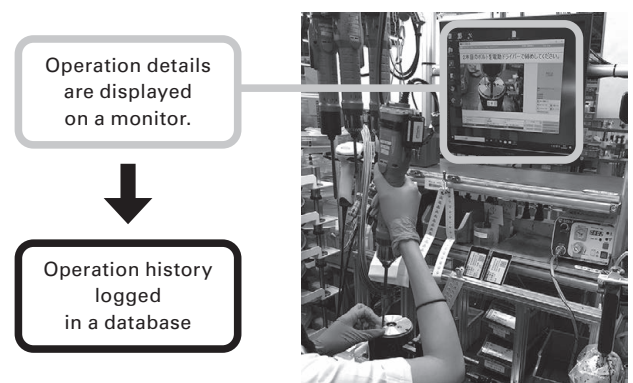

Fig. 7 Production guidance system

4.1.2 Building operator guidance systems^(note 3)

In conventional operations, when a single operator managed multiple devices during production, it was the operator's responsibility to decide when to switch between the devices. However, poor timing often led to wait times, lowering productivity.

To resolve this issue and allow efficient workflows, we have built an operator guidance system.

(note 3) Patent application being processed

As shown in Figure 8, this system uses guide lights to signal when operators should switch between devices. When it is time to switch, the guide light blinks, prompting the operator to move to next device. Simultaneously, the guide light on the previously operated device turns off, and the device is locked to prevent unauthorized operation.

By introducing this system, operators can now switch between devices at the optimal time, eliminating wait times. As a result, production efficiency has improved by 42%, thereby optimizing the use of both energy and resources.

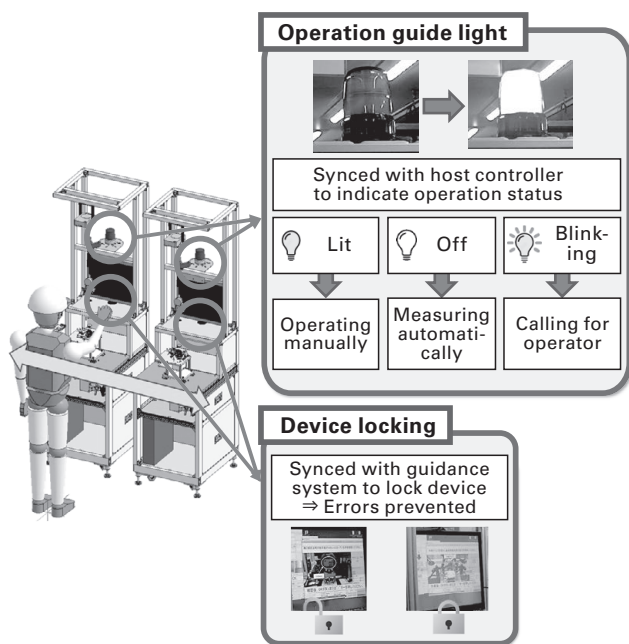

Fig. 8 Overview of operator guidance system

4.1.3 Development of measurement value monitoring system

We have developed a system for real-time monitoring of measurement values in the adjustment and inspection processes for encoders.

This system, shown in Figure 9, allows users to graphically display changes in measurement values by selecting the

monitoring period, device, and criteria.

Previously, when a defect occurred, the personnel had to perform multiple tasks, including collecting measurement values, comparing them with standard values, and analyzing changes in measurement data before and after the defect to identify the root cause.

With this system, the time required for defect analysis has been reduced by over 80%, enabling more efficient solution and countermeasure development.

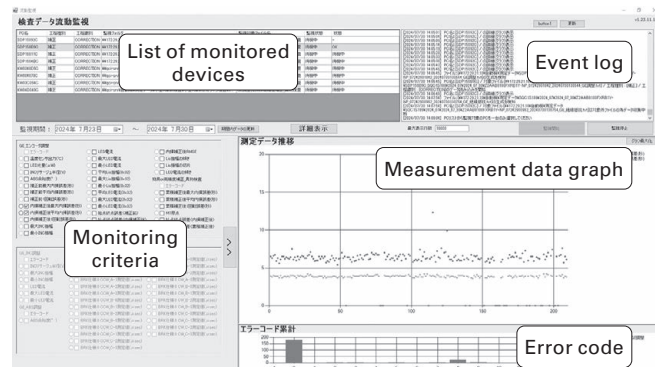

Fig. 9 Measurement value monitoring system

Additionally, we accumulate and analyze data to identify opportunities for process improvements. The system also supports trend analysis of measurement values to enable preventative measures, such as detecting deterioration in inspection equipment and jigs.

Through these initiatives, we reduce waste and environmental impact to promote sustainable manufacturing.

4.2 Building automated production lines

To realize efficient production and optimal personnel allocation, we have built automated production lines. In the automated production line for DC servo motors shown in Figure 10, individual stations for loading and inspecting workpieces are arranged in a single row, enabling automatic transport of products using pallets and automatic connections to inspection equipment.

In this line, product serial numbers serve as keys to retrieve product data from a database, automatically setting the standard inspection values and inspection details for each model.

This automation integrates transportation and inspection processes into a seamless workflow. This enhances production efficiency in high-mix, low-volume manufacturing and optimizes the use of both energy and resources.



Fig. 10 Automated production line for DC servo motors

5. Conclusion

This article has presented three initiatives involving SANMOTION products that align with our corporate philosophy and support the achievement of the SDGs:

- (1) We introduced a proposal for a broccoli harvesting robot, a type of agricultural equipment designed to address the labor shortage in agriculture and contribute to stable food supplies.
- (2) We showcased efforts such as utilizing the new wing of the Technology Center, joint development with the Design Department of SANYO DENKI PHILIPPINES, INC., and leveraging simulation technology. These initiatives have fostered fulfilling workplaces, enhanced employees' skills, and strengthened design and development capabilities.
- (3) We detailed examples of automated production lines and introducing systems to efficiently manufacture SANMOTION products. These efforts support sustainable manufacturing, allowing us to continue providing socially valuable products while promoting sustainability.

As described above, we aim to keep the SANMOTION products closely tied to the SDGs, contributing to the realization of a "sustainable and prosperous society." Our goal is to create servo system products that contribute to a "society in which all people achieve happiness."

Note: The company names and product names listed in this article are the trademarks or registered trademarks of their respective owners.

Reference

Yasushi Misawa and 15 others: "Development of the SANMOTION G AC Servo Systems"

SANYO DENKI Technical Report No. 54 pp. 45-56 (2022.11)

Author

Naohiro Ito

Design Dept., Electronics Company

Engages in the development and design of servo amplifiers.

Koji Nakatake

Design Dept., Motion Company

Engages in the development and design of stepping motors.

Takahiro Yoneta

Production Engineering Dept., Motion Company

Engages in the production engineering of servo motors and stepping motors.

Expanded Lineup of the *SANMOTION G* AC Servo Systems

Tsuyoshi Kobayashi Hiroshi Kanai Masaaki Mizusawa Yuta Imai
 Yasuhiro Wakui Hideaki Nishizawa Keisuke Ishizaki Kazuki Fujita
 Akihiro Matsumoto Yasushi Misawa Takuya Saito Tomohiro Harada

1. Introduction

Servo systems serve as key elements in equipment and directly impact on the performance, quality, and reliability of our customers' equipment. Customers demand high responsiveness and precise tracking performance, excellent maintainability, and energy-efficient products that support carbon neutrality.

In 2022, we launched the *SANMOTION G* servo systems combining powerful and user-friendly features. The lineup includes servo motors with rated outputs ranging from 30 W to 1.5 kW and servo amplifiers with output currents ranging from 10 to 50 A. Widely adopted by our customers, these products have contributed to reducing the size and weight of machines while enhancing functionality and performance.

We have recently developed servo motors with rated outputs ranging from 1.8 kW to 5 kW and servo amplifiers with output currents of 75, 100, and 150 A, expanding our lineup with models designed to meet the need for larger machines and equipment.

This article will first provide an overview of the newly developed products. Next, we will introduce the powerful and user-friendly features of these products, as well as the key development points.

2. Product Overview

The following is an overview of the servo motors, encoders, and servo amplifiers that have been added to the lineup of *SANMOTION G* AC servo systems.

2.1 Servo motors

Figure 1 shows some of the new servo motors. The newly added lineup includes low-inertia and medium-inertia products, as shown in Table 1 and Table 2, respectively.

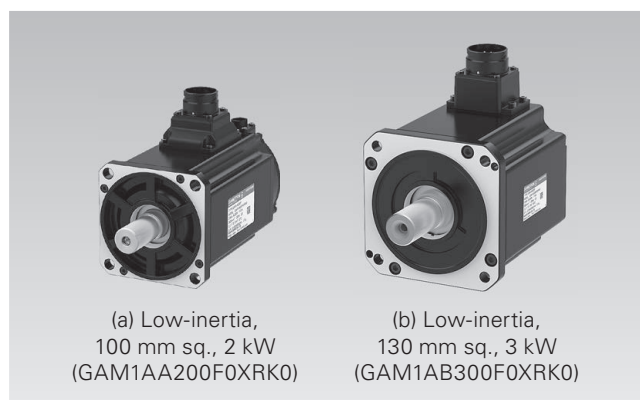

Fig. 1 Servo motor appearance

Table 1 Servo motor lineup (Low-inertia)

Flange Size	Rated output	Power supply voltage	Servo motor model no.	New model added
		200 V		
100 mm sq.	2 kW	✓	GAM1AA200F0	–
		✓	GAM1AA200H0	–
	2.5 kW	✓	GAM1AA250F0	–
		✓	GAM1AA250H0	–
130 mm sq.	3 kW	✓	GAM1AB300F0	–
		✓	GAM1AB300H0	–
	4 kW	✓	GAM1AB400F0	–
		✓	GAM1AB400H0	–
	5 kW	✓	GAM1AB500F0	–
		✓	GAM1AB500H0	–

Table 2 Servo motor lineup (Medium-inertia)

Flange size	Rated output	Power supply voltage	Servo motor model no.	New model added
		200 V		
130 mm sq.	1.8 kW	✓	GAM2AB180D0	–
		✓	GAM2AB180H0	–
	2 kW	✓	GAM2AB200D0	–
		✓	GAM2AB200H0	–
	3 kW	✓	GAM2AB300B0	✓

Table 3 Servo motor (typical models) and encoder specifications

Servo motor model no.			Low-inertia: GAM1A					Medium-inertia: GAM2A			
			A200F0	A250F0	B300F0	B400F0	B500F0	B180D0	B200D0	B300B0	
Flange Size	–	mm	100 sq.	100 sq.	130 sq.	130 sq.	130 sq.	130 sq.	130 sq.	130 sq.	
Rated output	P _R	kW	2	2.5	3	4	5	1.8	2	3	
Rated torque	T _R	N·m	6.37	7.97	9.7	12.8	16.0	8.6	9.5	14.4	
Continuous stall torque	T _S	N·m	6.37	7.97	9.7	12.8	16.0	10.0	12.0	16.0	
Peak stall torque	T _P	N·m	20.0	24.0	29.0	39.0	48.0	25.5	31.0	47.3	
Rated speed	N _R	min ⁻¹	3,000	3,000	3,000	3,000	3,000	2,000	2,000	2,000	
Maximum speed	N _{max}	min ⁻¹	6,500	6,500	6,000	6,000	6,000	5,000	5,000	3,000	
Rotor inertia	w/o brake	J _M	×10 ⁻⁴ kg·m ² (GD ² /4)	2.30	2.80	7.00	8.80	10.6	11.5	15.0	18.7
	with brake			2.59	3.11	8.00	9.88	11.8	12.5	16.2	19.8
Encoder inertia	J _S			0.0025	0.0025	0.0105	0.0105	0.0105	0.0105	0.0105	
Motor length	w/o brake	LL	mm	167.5	187.5	184	208	232	125.5	163	178
	with brake			204	224	227	251	275	150.5	216	231
Mass	w/o brake	W _E	kg	5.7	6.7	9.7	12.2	14.3	6.9	8.4	9.8
	with brake			7.2	8.2	12.2	14.7	16.8	8.5	11.0	12.4
Encoder resolution	–	–	17-bit (131,072 bits per revolution), 20-bit (1,048,576 bits per revolution), 23-bit (8,388,608 bits per revolution), 27-bit (134,217,728 bits per revolution)								
Multi-turn encoder	–	–	Batteryless								

Note: Custom options are available in with/without holding brake, with/without oil seal, and circular/keyway shaft.

A total of 15 models have been added to the servo motor lineup: 10 low-inertia models ranging from a 100 mm sq., 2 kW model to a 130 mm sq., 5 kW model, and five medium-inertia models of 130 mm sq. ranging from a 1.8 to 3 kW model. We used push-pull type connectors for the power and encoder cables, which allows simple and secure coupling.

The introduction of the 130 mm sq., 3 kW model enables these motors for use in larger machines and equipment compared to our current *SANMOTION R* series motors⁽¹⁾.

Table 3 shows the specifications of representative servo motors and encoder models. The motor encoders are equipped with a compact, thin serial encoder featuring a high resolution of up to 27 bits per revolution, available as either a battery-less absolute encoder or a single-turn absolute encoder.

2.2 Servo amplifiers

Table 4 shows the new models added to the servo amplifier lineup, which are available in 75, 100, and 150 A output currents. The lineup has been expanded with the addition of a total of 9 models with the interface available in two types—EtherCAT⁽²⁾ and analog/pulse train command input types.

A terminal block was conventionally used for the wiring of the power input and motor power, but it has now been replaced with a connector as shown in Figure 2, facilitating wiring work.

As shown in Figure 3, the housing for the 100 and 150 A models of our current servo amplifiers⁽³⁾ is made up of sheet metal and extruded fins. On the new product, it has been replaced with a resin housing with die-cast fins. This resulted in up to 19% lighter amplifier weight without

Table 4 Servo amplifier lineup

Servo motor	Servo amplifier (200 V power supply voltage input)				
	Compatible motor rated output	Output current	Model no.	Interface(GPO type)	
				EtherCAT	Analog/Pulse
Up to 3 kW	75 A	GADSA07*A**	–	Sink output	
		GADSA07*B**	–	Source output	
		GADSA07*H**	✓	–	
Up to 5 kW	100 A	GADSA10*A**	–	Sink output	
		GADSA10*B**	–	Source output	
		GADSA10*H**	✓	–	
Up to 7 kW	150 A	GADSA15*A**	–	Sink output	
		GADSA15*B**	–	Source output	
		GADSA15*H**	✓	–	

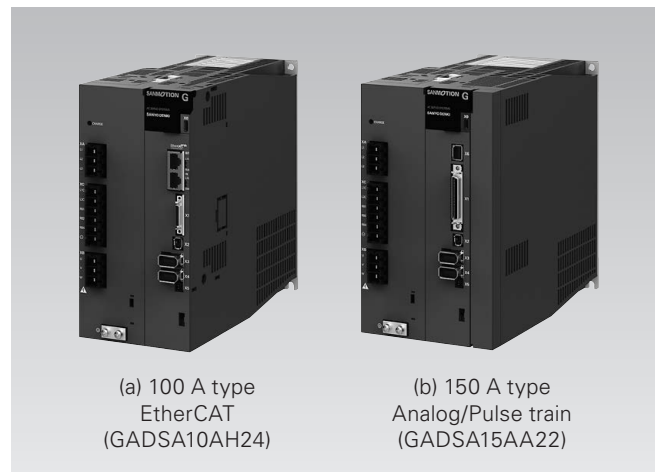

Fig. 2 Servo amplifier appearance

compromising the strength.

Table 5 shows the specifications of the servo amplifiers. In addition to improved responsiveness, high tracking performance and short settling time have been achieved through introduction of the feed-forward gain switching and

overshoot suppression functions. We have also improved the magnetic pole position estimations and low-noise mode to reduce noise and vibrations during operation. This can contribute to greater productivity and quieter operation for machines and equipment.

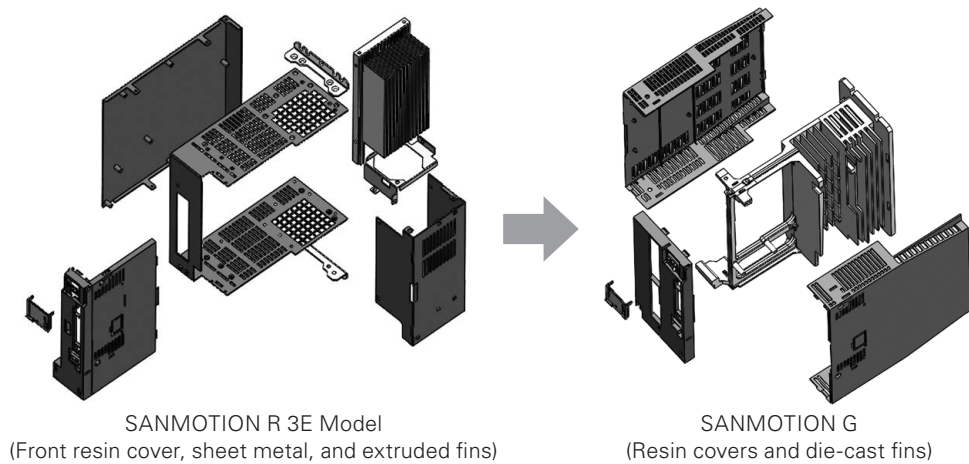

Fig. 3 Housings of current and new products

Table 5 Servo amplifier specifications

Amplifier capacity		75 A	100 A	150 A
Control power supply voltage range		200 to 240 VAC +10%, -15%		
Main circuit power supply voltage range		200 to 240 VAC +10%, -15%		
Dimensions (H × W × D)		205 × 75 × 190 mm	205 × 100 × 220 mm	205 × 120 × 220 mm
Mass		2.4 kg	3.4 kg	4.2 kg
Continuous output current		18.0 Arms	24.0 Arms	34.0 Arms
Peak current		63.2 Arms	77.7 Arms	116.9 Arms
Compatible motors		Up to 3.5 kW	Up to 5.0 kW	Up to 7.0 kW
Compatible encoders		<ul style="list-style-type: none"> Absolute encoders (battery-less, single-turn, and battery backup types) Wire saving incremental encoder HEIDENHAIN's EnDat2.2 encoder 		
Ratings and functions	Responsiveness and maximum applicable resolution	<ul style="list-style-type: none"> 1,070 Hz (speed loop frequency response) 134,217,728 steps per revolution (27 bit) 		
	Control functions, compensation functions	<ul style="list-style-type: none"> Tandem operation control Friction compensation Overshoot suppression Magnetic pole position estimation (position feedback) Dual position feedback control Gravity compensation Encoder resolution shifting Quadrant projection compensation Disturbance observer Low-noise mode 		
	Interface	<ul style="list-style-type: none"> EtherCAT, analog/pulse train command input 		
	Mechanical vibrations, resonance suppression	<ul style="list-style-type: none"> Model-following vibration suppression CP vibration control Torque command notch filter (variable width) FF vibration suppression Minor-vibration control Adaptive notch filter 		
	Servo tuning	<ul style="list-style-type: none"> Frequency characteristics measurement Auto tuning responsiveness (7 characteristics, 40 levels) Advanced tuning 		
Compliance with standards	UL/cUL	UL 61800-5-1 / C22.2 No.274-13		
	Low Voltage Directive / EMC Directive	EN 61800-5-1 / EN 61800-3, EN 61326-3-1		
Other	Functional safety	ISO 13849-1 PL=e, EN 61508 SIL3, EN 62061 SILCL3		
	KC Mark	KN 61000-6-2, KN 61000-6-4		
	Other	UKCA Mark, RoHS Directive		
Start-up, monitoring, diagnosis		<ul style="list-style-type: none"> Virtual motor operation System power consumption monitoring Control power supply frequency monitoring Remaining electrolytic capacitor life Regenerative resistor power consumption monitoring Encoder temperature monitoring Relay counter Drive recorder Input power supply monitoring Encoder/EtherCAT communication quality monitoring Remaining holding brake life Amplifier temperature monitoring Relay sticking detection 		

3. Powerful Servo Performance

3.1 Improved efficiency

For servo motors, we optimized the electromagnetic design and winding parameters to achieve a design that maximizes the performance of the material, resulting in a 3% improvement in efficiency compared to the current product.

3.2 Extended output range

Figure 4 shows a comparison of the torque vs. speed characteristics (T-N characteristics) of medium-inertia servo motors. With the servo motor winding optimized and the servo amplifier applying a higher voltage to the motor by improving the voltage utilization rate at high speeds—when voltage saturation occurs—the output range was increased by 10%.

By expanding the output range, acceleration time and deceleration time can be reduced.

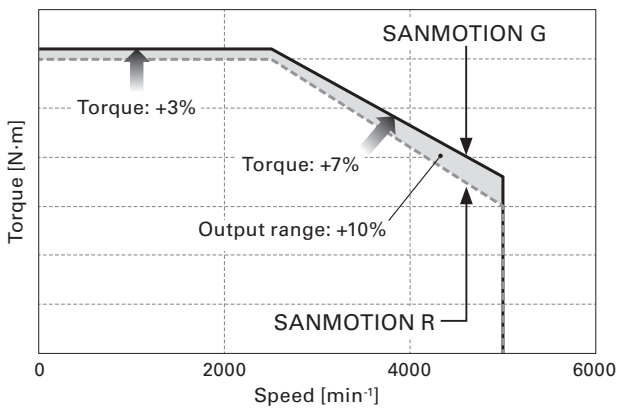

Fig. 4 Comparison of T-N characteristics of medium-inertia motors

3.3 Improved responsiveness and shortened positioning settling time

Figure 5 compares the closed-loop frequency response characteristics of the speed control systems. By increasing the power device switching frequency, speeding up the control cycle, and boosting the current detection precision, we have improved the speed loop frequency response to 1.4 times (to 1,070 Hz) that of the current product.

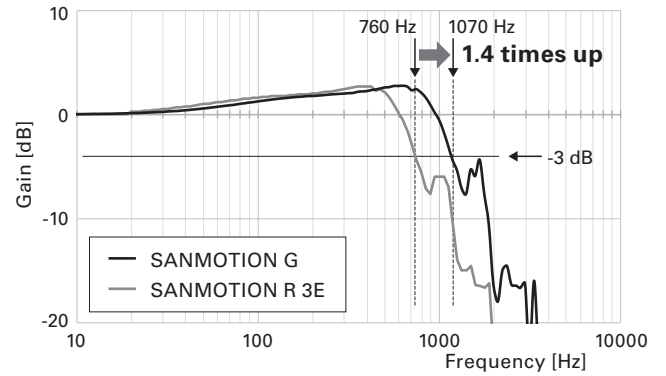

Fig. 5 Comparison of closed-loop frequency response for the speed control system

In addition, we have added a feature for switching feed-forward gain. As shown in Figure 6, this shortens the positioning settling time to 1/3 of the current product, which lacks this feature. This shorter settling time reduces the cycle time of machines and equipment, increasing the system efficiency and productivity.

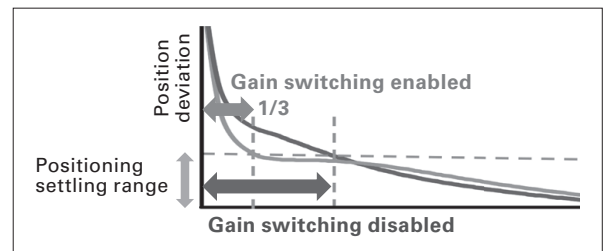

Fig. 6 Positioning settling characteristics

3.4 Enhanced environmental durability

Table 6 compares the environmental durability of the new product with the current product. During the product design phase, we improved the environmental durability by conducting structural strength simulations and thermal simulations, combining verification testing with actual equipment.

This enables use at altitudes of up to 2000 m. Moreover, compared to the current product, the motor's vibration resistance has been doubled to 50 m/s², making it suitable for use in harsher environments.

Table 6 Environmental durability comparison with current product

Items	Product	SANMOTION R (Current product)	SANMOTION G (New product)	Improvement
Altitude	Common	1000 m max.	2000 m max. (may require derating)	100% increase
Vibration resistance	Motor	24.5 m/s ² (10 Hz to 2 kHz)	50 m/s ² (10 Hz to 2 kHz)	100% increase
	Amplifier	4.9 m/s ² (10 Hz to 55 Hz)	6.0 m/s ² (10 Hz to 150 Hz)	22% increase
Temperature	Amplifier	0 to 55°C	0 at 60°C (may require derating)	9% increase
Humidity	Amplifier	90% RH or less (non-condensing, non-frozen)	95% RH or less (non-condensing, non-frozen)	5% increase

4. Powerful Reliability

4.1 Overshoot suppression

We have added an overshoot suppression feature to the servo amplifier's speed control. Figure 7 shows that the speed overshoot has been halved, improving the command-following performance. This reduces the processing time of machines that require high command-following performance such as semiconductor manufacturing equipment that involves photoresist coating and development

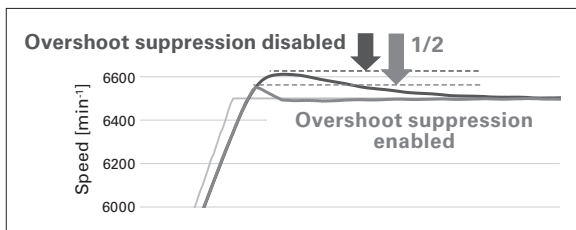

Fig. 7 Overshoot suppression characteristics

4.2 Encoder resolution shift

Increasing the encoder resolution improves repeatability and responsiveness. However, it also causes some challenges.

For example, with the EtherCAT interface, the actual position is represented by 32 bits as shown in Figure 8. Using a 27-bit/revolution encoder generally limits the multi-turn component to 5 bits for 32 revolutions, restricting the machine's moving range.

To address this, a function has been added to servo amplifier to shift encoder resolution. This allows the effective length of the multi-turn component to increase, expanding the machine's stroke even when using a high-resolution encoder.

Although the host controller's coordinate unit conversion must be adjusted for different resolutions, *SANMOTION G*

servo motors can replace existing motors without requiring significant changes.

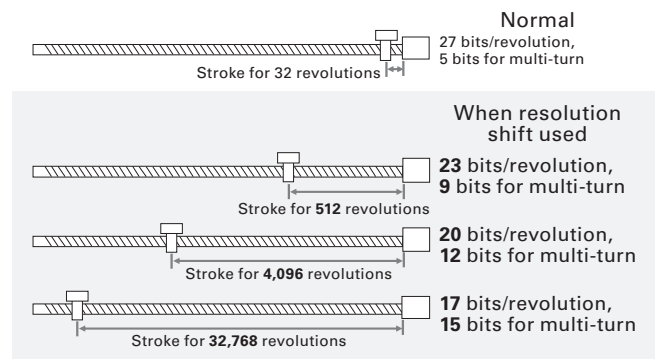

Fig. 8 Encoder resolution shifting illustrations

4.3 Preventive and diagnostics functions

Factors that result in power device errors include overcurrent, device control circuit errors, and overheating, which were difficult to identify with the current product. To improve diagnostics, we have classified alarms into three groups, as shown in Figure 9. The more detailed alarm descriptions allow for faster issue identification and quicker countermeasures, shortening equipment downtime.

Furthermore, we added an overload alarm generation rate monitoring feature. By determining the margin before an overload alarm is triggered, the servo motor can operate at an optimal cycle time, maximizing its performance.

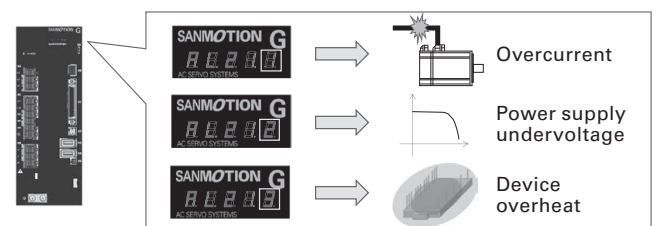

Fig. 9 Divided power device errors

5. Environmental Friendliness

5.1 High-efficiency, compact, lightweight servo motor

We optimized the electromagnetic design and winding parameters to achieve a design that maximizes the performance of the material, improving efficiency by 3%. The encoders were redesigned to be more compact and thin, reducing the motor’s length and weight. Figure 10 compares the length of the new and current motors, while Figure 11 compares their mass. The new motors are up to 9% shorter and 11% lighter, contributing to making customer equipment smaller and more energy-efficient.

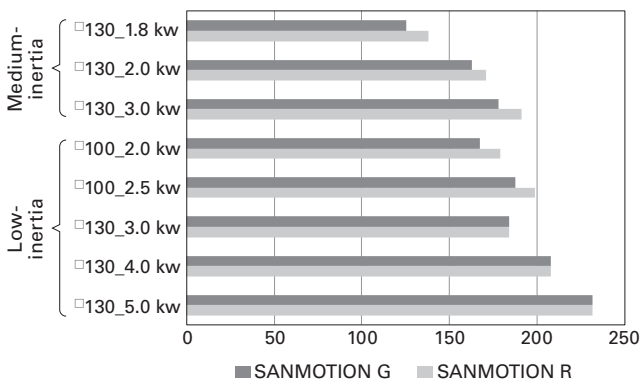

Fig. 10 Comparison of motor length (Without holding brake)

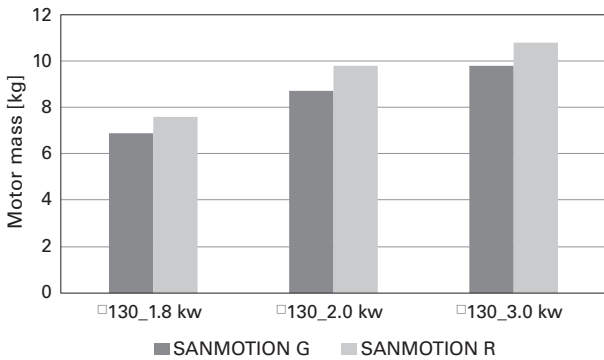

Fig. 11 Comparison of medium-inertia motor mass (Without holding brake)

5.2 High-efficiency, lightweight servo amplifier

As described earlier, we have increased the switching frequency by 12% to achieve higher responsiveness. Generally, high-speed switching leads to higher losses and lower efficiency. In this development project, however, we achieved both 12% faster switching and a 0.6% efficiency improvement by using the low-loss power device and reducing control circuit’s power consumption. In addition, we have

reduced the weight by up to 19% by changing the housing.

This contributes to improved energy efficiency and reduced weight in machines and equipment.

5.3 Overview of Eco Products (reduced CO₂ emissions)

We certificate energy-saving, eco-friendly products as Eco Products⁽⁴⁾ and Eco Products Plus⁽⁴⁾.

A life cycle assessment (LCA) compared the CO₂ emissions of the new and current products. The results for servo motors are shown in Figure 12, and for servo amplifiers in Figure 13. For the servo motors, we have achieved a 29% reduction in CO₂ emissions by optimizing the electromagnetic design and winding parameters to achieve a design that maximizes the performance of the material, which has earned them Eco Products certification. Notably, the 130 mm sq. medium-inertia servo motor has been awarded Eco Products Plus certification, which signifies even lower environmental impact.

For the servo amplifiers, we have achieved a reduction in CO₂ emissions by up to 19.4% by improving the energy conversion efficiency and reducing the weight, earning them Eco Products certification.

Both the servo motors and servo amplifiers can contribute to the realization of carbon neutrality.

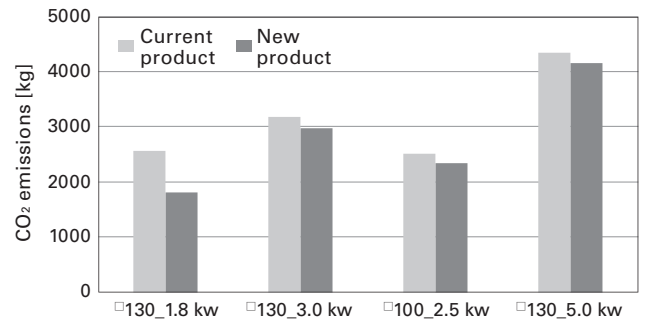

Fig. 12 Comparison of servo motor CO₂ emissions

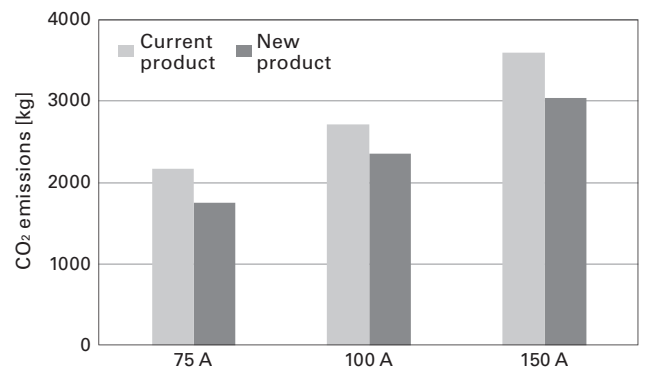

Fig. 13 Comparison of servo amplifier CO₂ emissions

6. User Friendliness

6.1 Mounting and replacement made easier

We replaced the screw-fitting type power connectors of the servo motors with circular push-pull connectors, making cable attachment more user-friendly. In addition, the flange dimensions, mounting dimensions, and output shaft shape have been made compatible with the current product for smooth replacement. The power connectors are also compatible with the current screw-fitting connectors.

6.2 Magnetic pole position estimation

For the linear servo motors without the Hall effect sensor, we have added a magnetic pole position estimation function with a short travel distance and minimal vibrations. This function has been achieved through feedback control of the position during magnetic pole position estimation. Compared to the current function, the travel distance during magnetic pole position estimation has been reduced to 1/1000, and vibration to 1/15. These enhancements make the servo motors suitable for applications like PCB inspection systems, where stroke width is limited.

6.3 Low-noise mode

Switching frequency noise can now be reduced by increasing the switching frequency when the servo motor stops.

As shown in Figure 14, we have added a function to adjust the switching frequency across all motor speed. This feature allows users to tailor the low-noise mode to their device's operation, reducing unpleasant high-frequency noise during low-speed operation.

It is especially useful in applications like collaborative robots and medical devices, ensuring safe and quiet operation near people and patients.

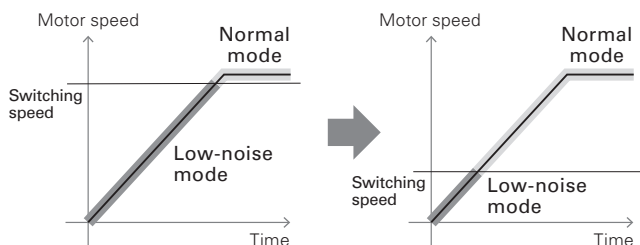

Fig. 14 Low-noise mode illustration

7. Key Points of Development

This chapter introduces the key development features and innovations we incorporated into our development work to achieve reductions in size and weight, lower heat generation, and greater production efficiency compared to the current product.

7.1 Shortened servo motor length

For the servo motors, we have optimized the electromagnetic design and winding parameters to achieve a design that maximizes the performance of the material to shorten servo motor length. While the current product has a simple structure with the encoder and cover stacked on a bracket, the new product integrates the encoder into the bracket itself. This new bracket structure significantly reduces the motor length, making our medium-inertia servo motors the shortest in the industry.

7.2 Revised servo amplifier housing

For the 100 and 150 A models, we used aluminum die-casting for the housing parts and resin covers for the sides. Due to larger mold components compared to the current product, we ensured to fill the material evenly when molding.

Figures 15 and 16 show the pressure distribution during material filling into the die casting mold. In the initial phase of development, the filling pressure was high in some parts, as shown in Figure 15. High filling pressures tend to cause insufficient filling during molding, leading to missing parts and significant dimensional errors in the molded product. Accordingly, we ensured the even material filling during molding by adding a bridge, as shown in Figure 16.

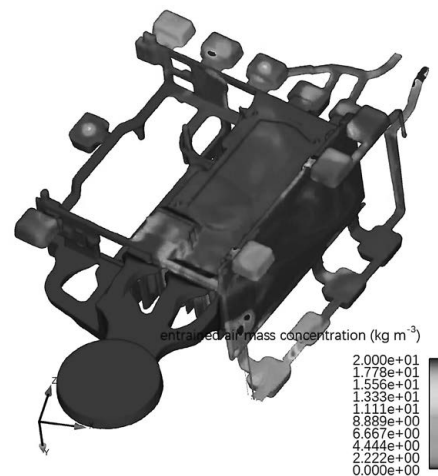

Fig. 15 Die casting fluid analysis (initial phase of development)

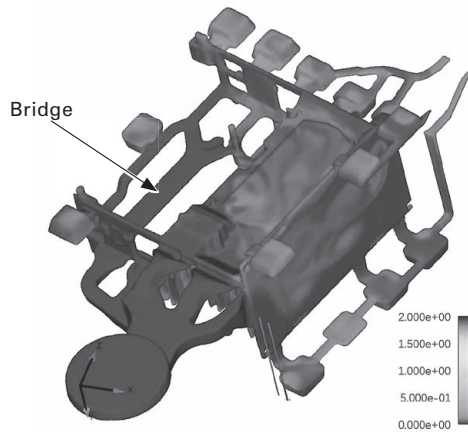

Fig. 16 Die casting fluid analysis (with bridge)

7.3 Servo amplifier assembly made easier

In the current product, the power treating board is separate from the power board for driving the servo motor. By using compact and low-loss semiconductors and replacing the cement resistors with chip resistors, we increased the density to consolidate the boards and reduced the harness. In addition, we adopted a housing made of a die-cast frame and resin covers to reduce the number of fixing screws.

These innovations have resulted in easier assembly, improving productivity.

7.4 Increased servo amplifier heat dissipation

To reduce the size and weight of servo amplifiers and improve the output density, we focused on suppressing temperature rise. We optimized the angle of the cooling fan to efficiently cool heat-generating components. Figure 17 shows the airflow of the cooling fan. This design ensures effective airflow and reduces temperature rise, improving the amplifier's thermal management.

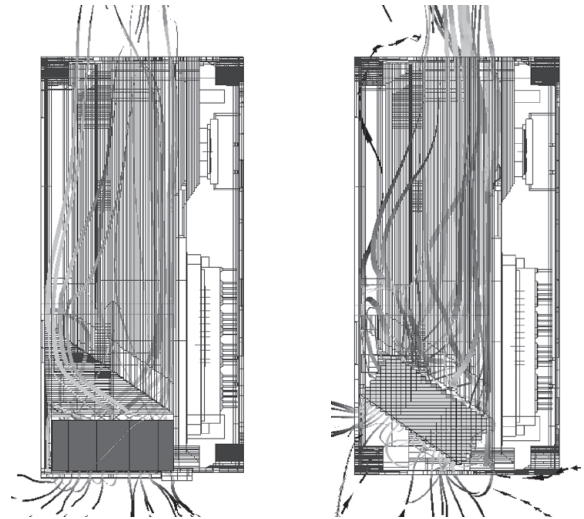

Fig. 17 Cooling fan airflow

8. Conclusion

We have expanded our lineup of *SANMOTION G AC* servo systems by adding servo motors with rated outputs ranging from 1.8 to 5 kW and servo amplifiers with output currents of 75, 100, and 150 A. Compared to the current products, the new product offers the following features.

- 1) The output range at high-speeds has been increased by 1.1 times. Encoder resolution has been enhanced by 16 times (up to 27 bits) and speed loop frequency response by 1.4 times (to 1,070 Hz).

This high tracking performance reduces acceleration and deceleration times, improving the productivity of machines and equipment.

- 2) The vibration resistance has been improved twofold for servo motors and by 1.2 times for servo amplifiers. The products are now usable at altitudes up to 2,000 m and have an expanded operating temperature range.

This allows the products to be used in harsher environments.

- 3) Functions have been provided to improve tracking performance and reduce noise.
 - Speed overshoot has been halved.
 - Travel distance and vibrations during magnetic pole position estimation have been reduced to 1/1000 and 1/15 respectively.
 - A new low-noise mode can freely change the switching speed.

This can contribute to improved performance and reduced noise in machines and equipment.

- 4) The new products offer compact, lightweight design with improved efficiency.

- Servo motors: Length reduced by 9%, weight reduced by 11%, and efficiency improved by 3%
- Servo amplifiers: Weight reduced by 19% and efficiency improved by 0.6%

These compact, lightweight, and efficient designs support the goal of carbon neutrality.

- 5) Push-pull type connectors for power and encoder cables of the servo motors ensure easy and secure connections. In addition, the mounting compatibility facilitates replacement of the current product.

These new AC servo systems feature upgraded servo performance and functions, which have enabled higher reliability, reduced size and weight, improved efficiency, and lower noise, resulting in a product that is both powerful and user-friendly.

We remain committed to advancing energy conversion efficiency, enhancing the performance of our customers' devices, and contributing to the realization of carbon neutrality.

Reference

Tsuyoshi Kobayashi and 16 others: "Development of the *SANMOTION G AC Servo Systems*"

SANYO DENKI Technical Report No. 54 pp. 45-56 (2022.11)

- (1) Current servo motors refer to SANMOTION R motors.
- (2) The company names and product names listed in this article are the trademarks or registered trademarks of their respective owners.
- (3) Current servo amplifiers refer to SANMOTION R 3E Model amplifiers.
- (4) Our products are assessed over the product's life cycle against our own eco-design requirements including product size, weight, power consumption, and CO₂ emissions, and those meeting our standards and higher standards qualify as Eco Products and Eco Products Plus, respectively.

Author

Tsuyoshi Kobayashi

Design Dept., Electronics Company

Engages in the development and design of servo amplifiers.

Hiroshi Kanai

Design Dept., Electronics Company

Engages in the development and design of servo amplifiers.

Masaaki Mizusawa

Design Dept., Electronics Company

Engages in the development and design of servo amplifiers.

Yuta Imai

Design Dept., Electronics Company

Engages in the development and design of servo amplifiers.

Yasuhiro Wakui

Design Dept., Electronics Company

Engages in the development and design of servo amplifiers.

Hideaki Nishizawa

Design Dept., Electronics Company

Engages in the development and design of servo amplifiers.

Keisuke Ishizaki

Design Dept., Electronics Company

Engages in the development and design of servo amplifiers.

Kazuki Fujita

Design Dept., Electronics Company

Engages in the development and design of servo amplifiers.

Akihiro Matsumoto

Design Dept., Electronics Company

Engages in the development and design of servo amplifiers.

Yasushi Misawa

Design Dept., Motion Company

Engages in the development and design of servo motors.

Takuya Saito

Design Dept., Motion Company

Engages in the development and design of servo motors.

Tomohiro Harada

Design Dept., Motion Company

Engages in the development and design of servo motors.

SANYO DENKI

Technical Report

58

November
2024

<https://www.sanyodenki.com/>

Published in Japan on November 15, 2024 by SANYO DENKI CO., LTD.
Published semi-yearly

3-33-1 Minami-Otsuka, Toshima-ku, Tokyo 170-8451, Japan
Phone +81 3 5927 1020
Publisher Nobumasa Kodama

Editorial Board Members:

Satoru Onodera	Editor-in-Chief
Yasutaka Narusawa	Managing Editor
Takashi Kobayashi	Secretariat
Shiho Tsukada	Secretariat
Risa Inamura	Secretariat
Kakuhiko Hata	
Sho Matsushita	
Hiroshi Sakaba	
Makoto Ishida	
Daigo Kuraishi	
Yoshiyuki Usui	
Hitoshi Yoshiike	
Rieko Komine	
Satoshi Inaba	

Copyright © 2024 SANYO DENKI CO., LTD.
All rights reserved.

No part of this publication may be reproduced in any manner whatsoever without written permission from SANYO DENKI.

All company and product names used in this publication are trademarks or registered trademarks of their respective companies.